

Manual

Linear Light System



	Page
Manual Veko linear lighting system IP40	
Installation of linear lighting	4
Installation of connecting pieces	6
Overview of brackets and connecting pieces	7
Power feed plastic housing with cable gland	8
Power feed aluminium housing with cable gland	9
Single unit (re-)placement	11
Manual Veko linear lighting system IP54	
Installation of linear lighting	13
Installation of connecting pieces	15
Overview of brackets and connecting pieces	16
Power feed with cable gland	17
Power feed Wieland	18
Single unit (re-)placement	20
Pool application	21
Manual Veko linear lighting system IP65	
Installation linear lighting	23
Installation of connecting pieces	25
Overview of brackets and connecting pieces	26
Power feed with cable gland	27
Power feed Wieland	28
Single unit (re-)placement	29
Pool application	30
Manual installation Veko Sensor	31
Manual configuration MD-L-N / MD-L-R	32
Decentral emergency lighting	33
Emergency system info & disclaimer	35
General disclaimer	36

This manual is for usage with shown product families on this page in IP40 specifications only.

In combination with the following linear lighting profiles:

- PNR-05500
- PNR-05515/*
- PNR-05532/*
- PNR-05500-B
- PNR-05532-B/*

To view the most recent version, scan the QR code below:



Magnus

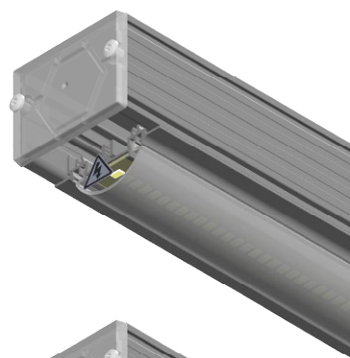

Duncan

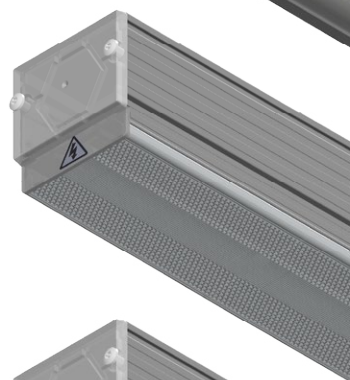

Joris

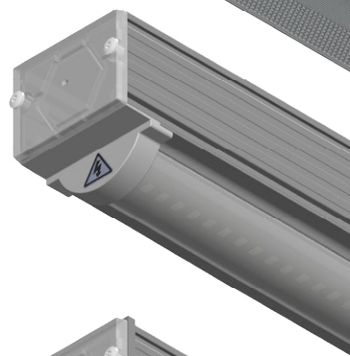

Rowan

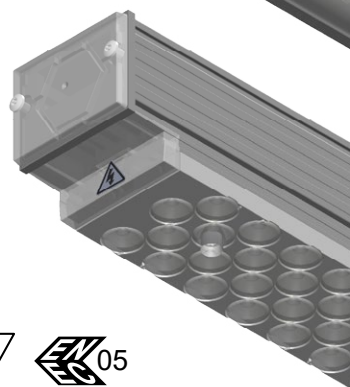

* Indicated profiles apply, regardless of the indicated amount of spacers on the profile (PNR-.../0~/1~/2).

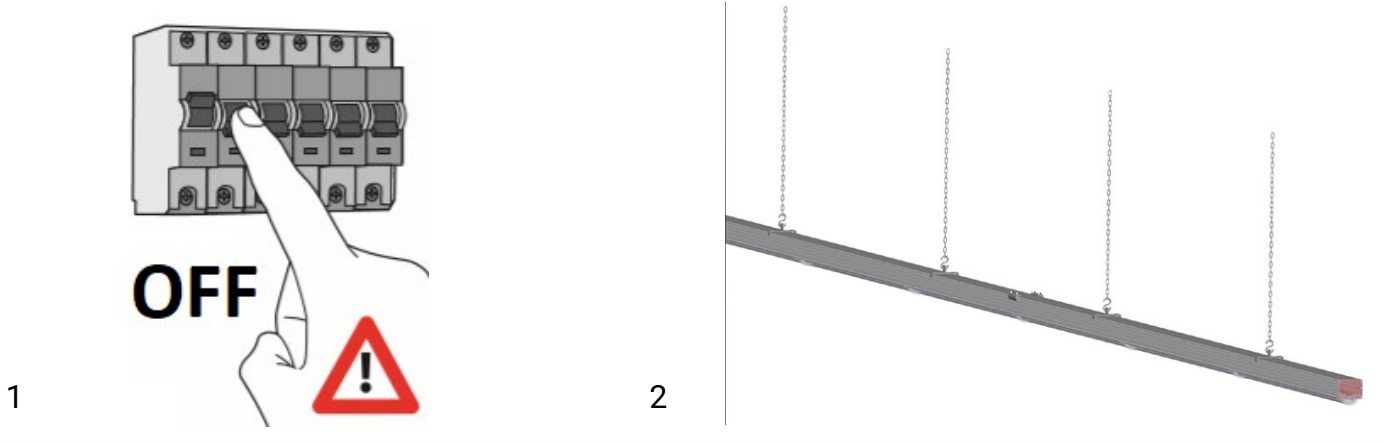

Regular conditions

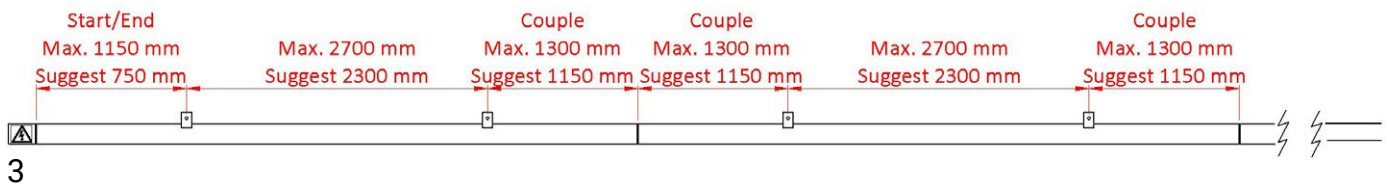

Sport/Cable tray/Swimming pool/6 m+

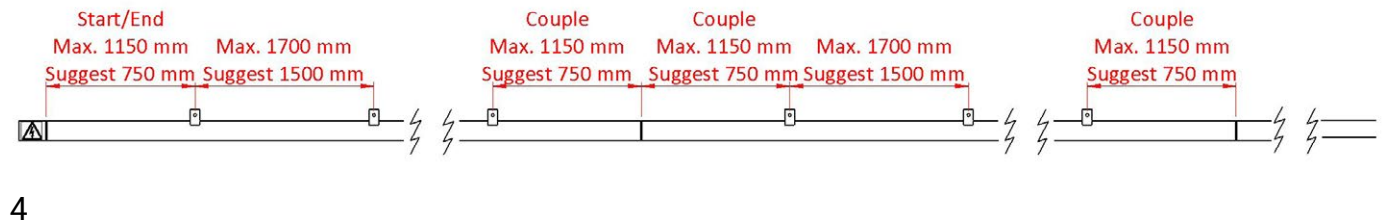

1. Disconnect the mains.

2. Example of a light-line.

3. In regular conditions:

- All line parts must be attached with at least 2 suspension points.
- Keep indicated suggested dimension for optimal suspension and quick assembly.
- Keep the same distance for the first and last suspension point.

- Keep the same distance between the coupling piece.

4. In case of Sports utility, Cable duct, Swimming pool, 6 m+:

- Sports/cable tray/swimming pool All line sections must be attached with a minimum of 3 suspension points.
- 6 m+ All line sections must be attached with a minimum of 4 suspension points.

- Keep specified suggested dimension for optimal suspension and quick assembly.

- Keep the same distance between the first and last suspension point.

- Keep the same distance between the coupler.

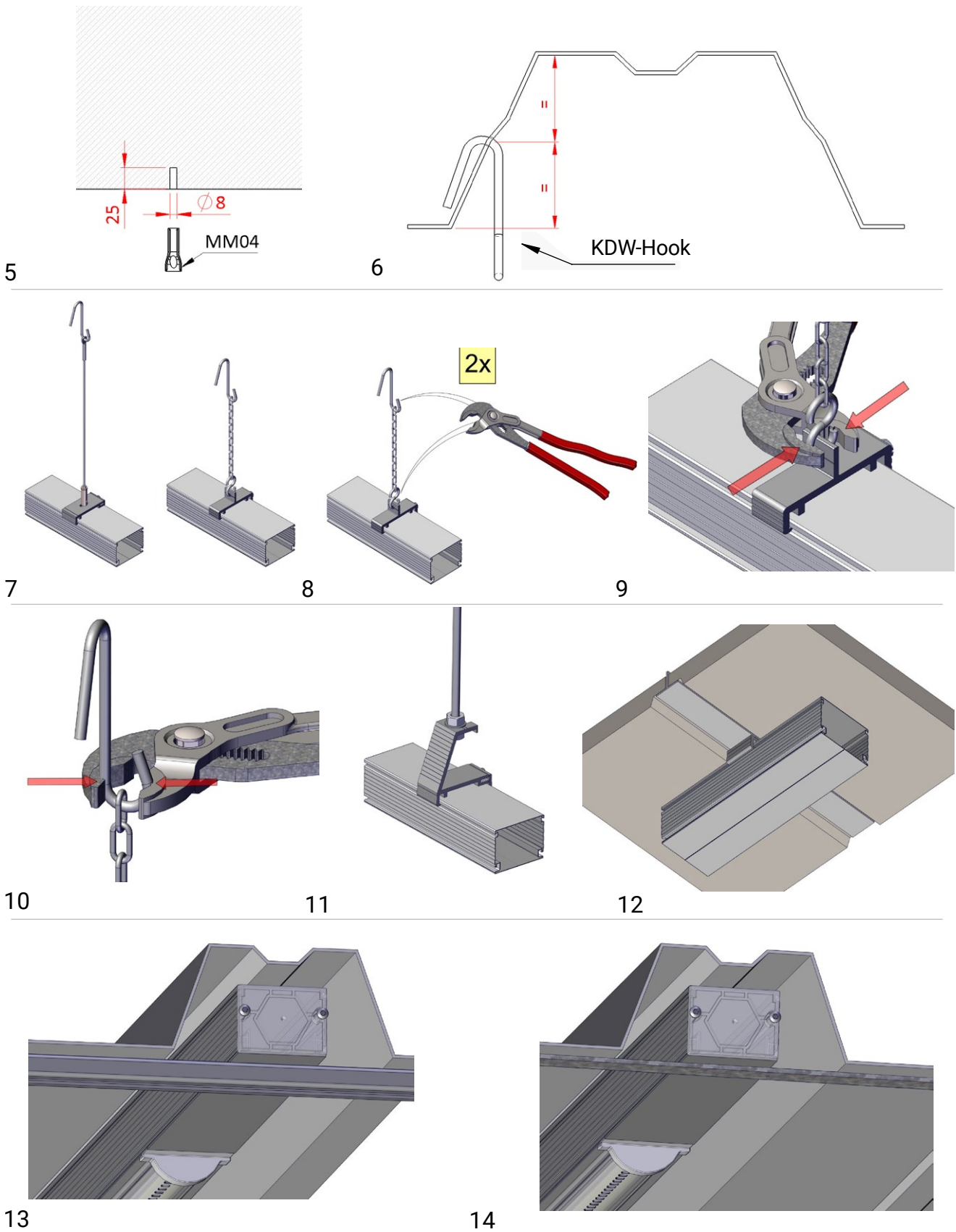

- 5. In case of mounting in concrete ceiling, Veko recommends a MM04 anchor or similar with according drill sizes.
- 6. In case of using a hook on a sheet piling roof structure, Veko advises to drill the hole in the center of the profile.
- 7. Example with KDW-hook, pendula and steelwire (left). KDW-hook, chain

- and S-hook (right).
- 8. Always close the links of both the KDWand and S-hook.
- 9. Close the link of the S-hook.
- 10. Close the link of the KDW-hook.
- 11. Example of mounting with threaded end.
- 12. Example of mounting with caddy.

- 13/14. When the linear lighting is placed inside the cannellure of the sheet piling, it's recommended to use a metal strut or strip to secure the linear lighting to the metal roof structure.

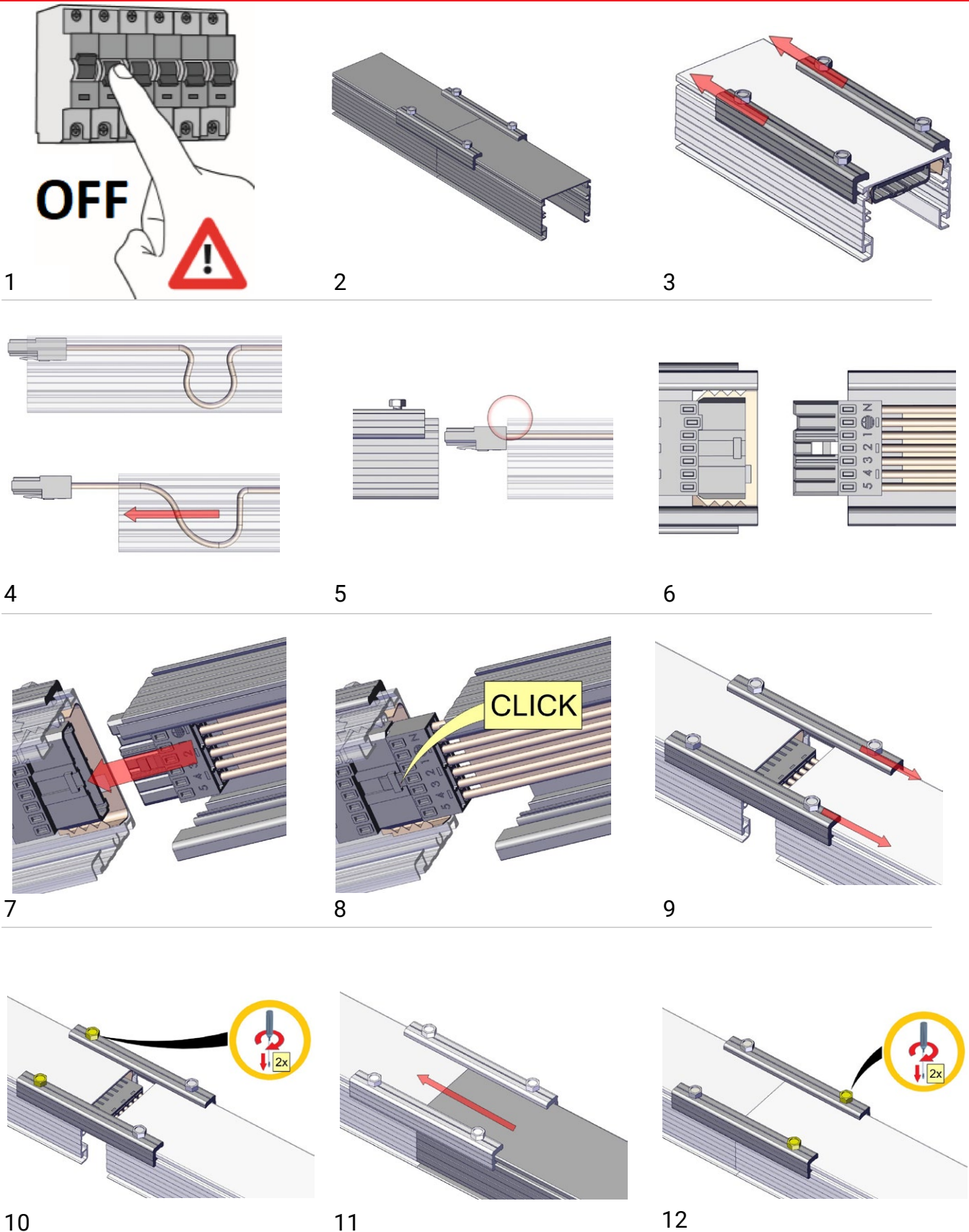













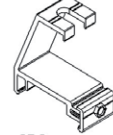

1. Disconnect the mains before operating the linear lighting system.
2. Example of connected profiles. **Note:** profile and/or brackets may vary.
3. Slide the provided bracket(s) completely onto one of the profiles.
4. The flatcable is provided with a curl for extra length for an easy connection.

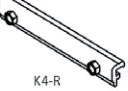
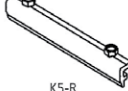
5. Pull out and extend the flatcable.
6. Make sure the male connector is positioned outside the profile, with the backside onto the edge of the profile.
7. Align both profiles.
8. Insert the connector.
9. Make sure connectors firmly 'click' into

- each other.
10. Slide bracket(s) back and equally divided over both profiles.
11. Tighten screws (2x).
12. Press profiles together.
13. Tighten screws (2x).



Profile	Brackets	Connecting pieces
 PNR-05500  PNR-05500-B	 B1-R  B7-SO-R  B7-R  B0-60 (adjustable angle)  B3-R  B3-CR	 K4-R  K5-R
 PNR-05515/*  PNR-05532/*  PNR-05532-B/*	 B2-733-R  B2-SO-733-R	

* Indicated brackets for profiles with cable gutter apply, regardless of the indicated amount of spacers on the profile (PNR-.../0~/1~/2).

Note: applicability of bracket may vary, depending on the surrounding, light line configuration, light line application and/ or IP-class.

Note: K4-R and K5-R brackets are available in various lengths, so the amount of used screws may vary from illustrated as above.



Item	Qty.
Housing top	1x
Housing bottom	1x
Connector female	1x
Connector male	1x
Cable gland M25	2x
Screw TX15	5x

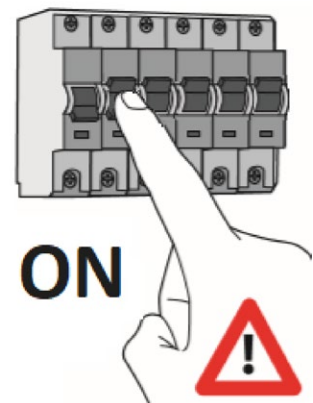
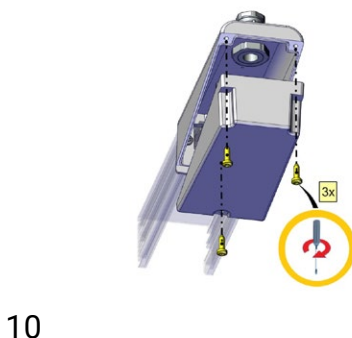
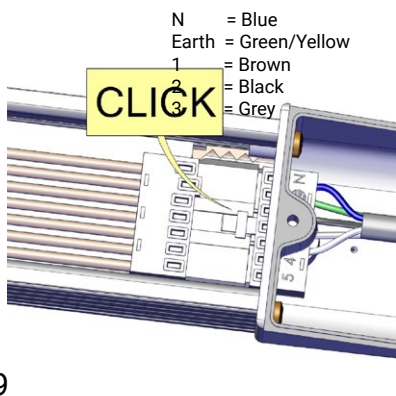
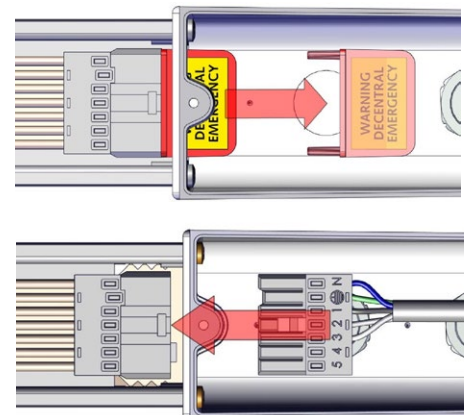
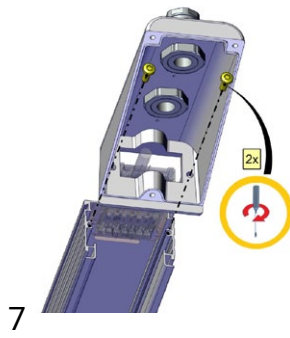
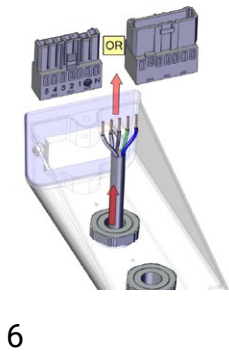
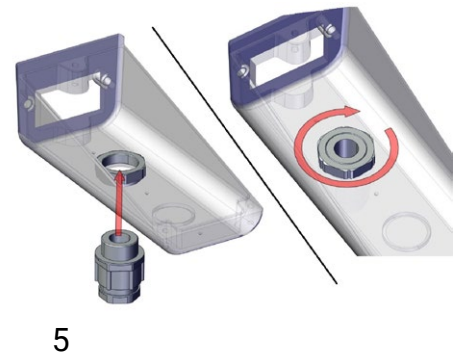
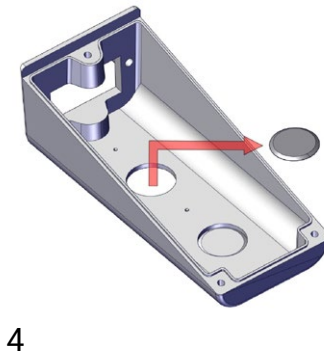
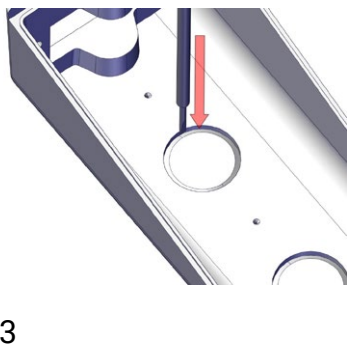
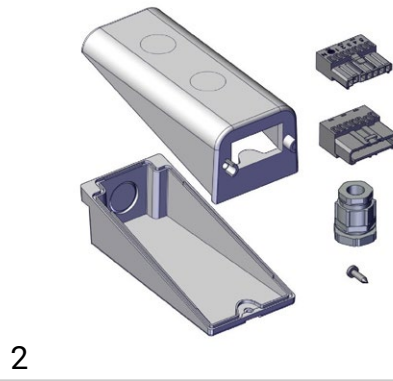
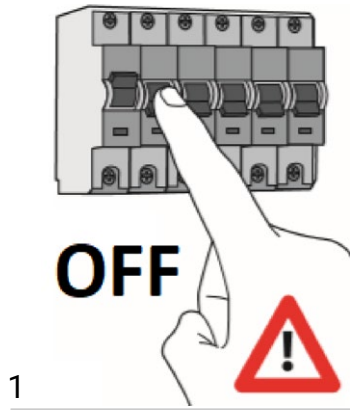

1. Switch off the mains before operating the linear lighting system.
2. Contents.
3. Use a slotted screwdriver to punch out the desired hole(s) for the cable gland(s).
4. Remove the remaining piece(s).
- 5A. Fit the cable gland(s).
- 5B. Fasten the cable gland nut(s).
6. Route wiring through the cable gland and

7. Mount the upper housing onto the light line and tighten screws (2x).
8. Connect the wiring to the flatcable of the light line. Remove plug when final power grid connection is made.
9. Make sure connectors firmly 'click' into

- each other.
10. Mount the lower housing onto the upper housing and tighten screws (3x).
11. After reassuring all electrical connections are correctly in place and corresponding, switch the mains back on.

Item	Qty.
Power feed	1x
Coupling plate (with 2x slotted M5 bolt)	2x

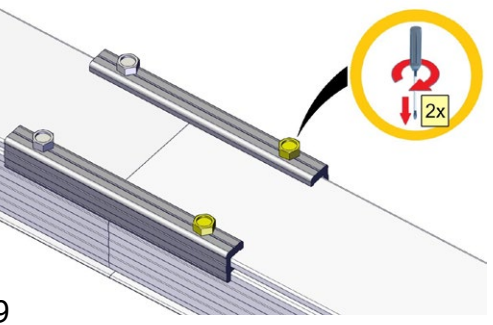
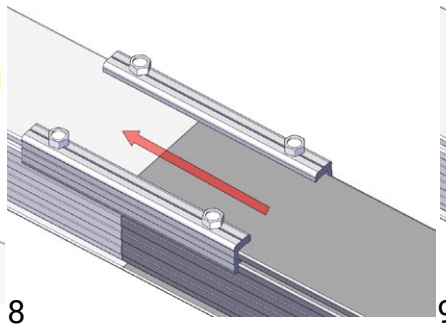
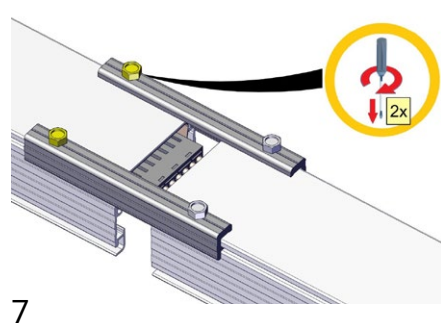
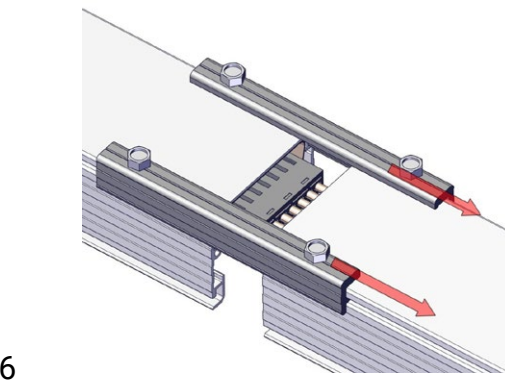
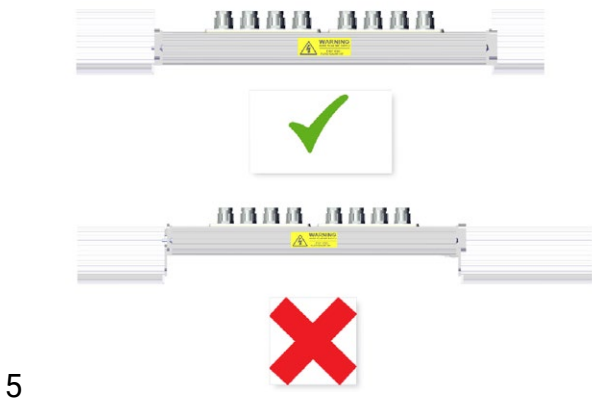
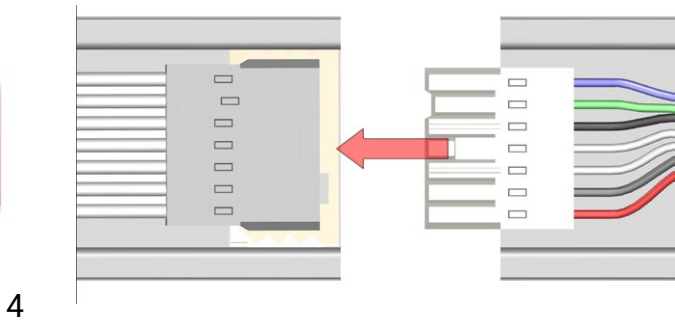
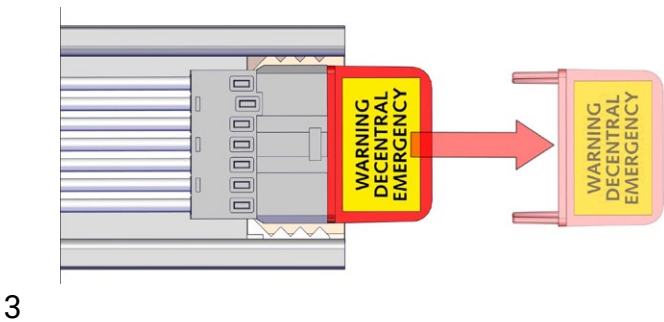
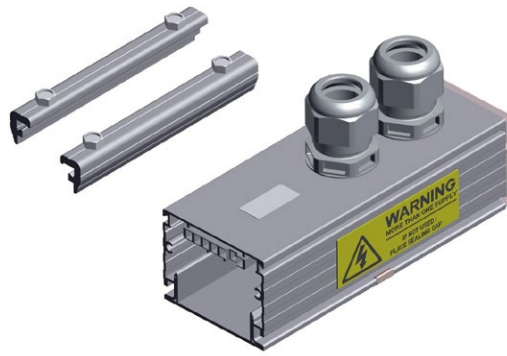
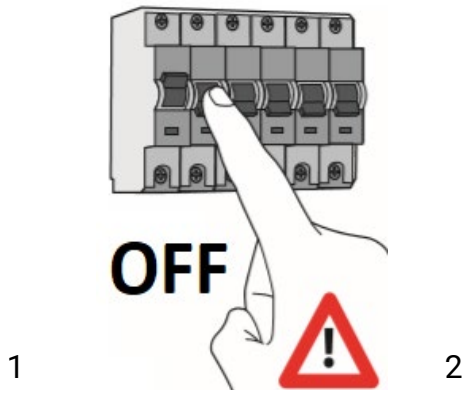

1. Turn off the power before connecting the lighting system.
2. The components
3. Remove the plug after the final connection to the power network is made.
4. Place the power supply on the light line. Connectors should 'click' together firmly.

5. For a profile with cable tray, place the power supply at the same height as the underside of the light line.
6. Slide the connectors back and slide them evenly over both profiles.
7. Tighten the screws (2x).
8. Connect the profiles against each other.

9. Tighten the screws (2x).

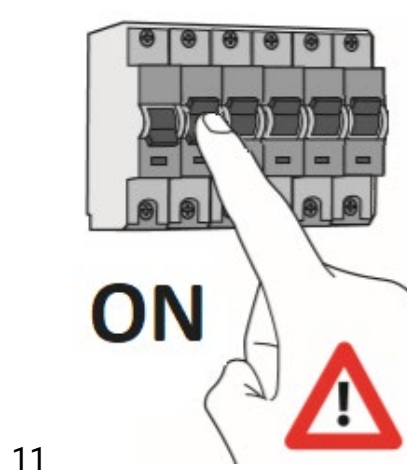
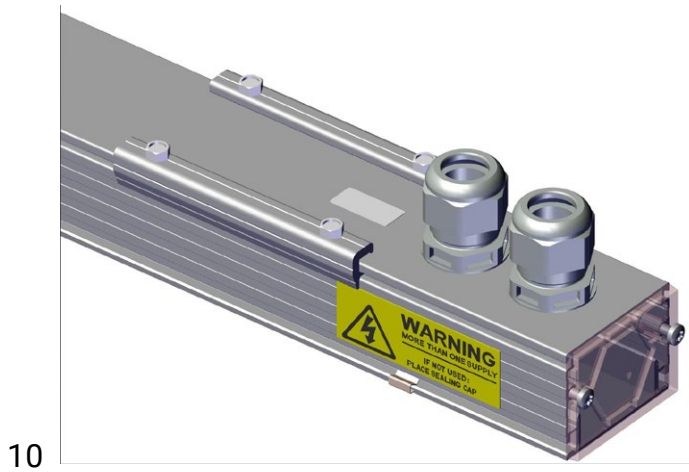

- 10. Connect the external wiring with the connectors to the power supply.
- 11. Are all electrical connections correctly in place? Then switch on the power supply.

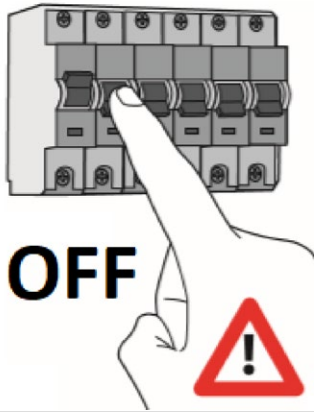

1



2

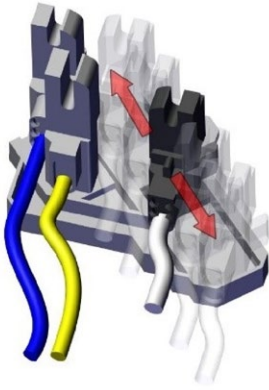

3

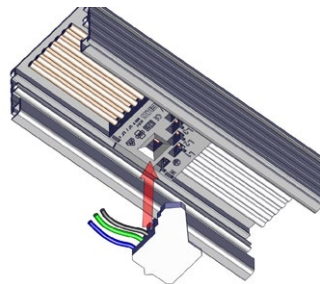

4

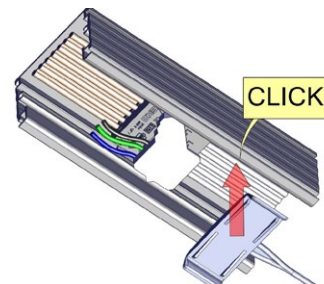

5

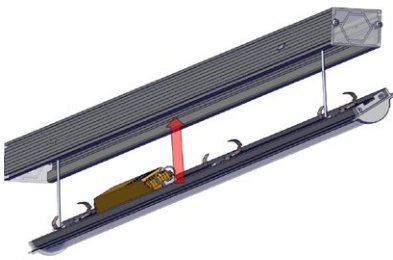

6



7

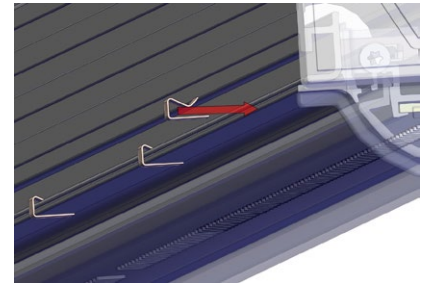

8a (sports & emergency units)

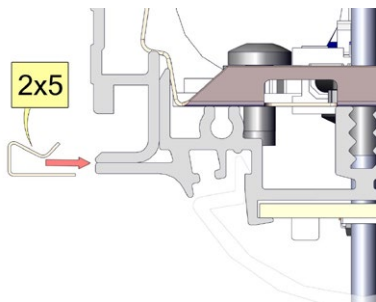

8b (sports & emergency units)

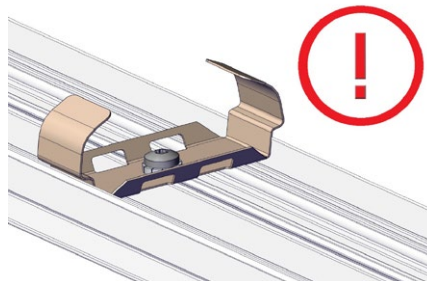

9

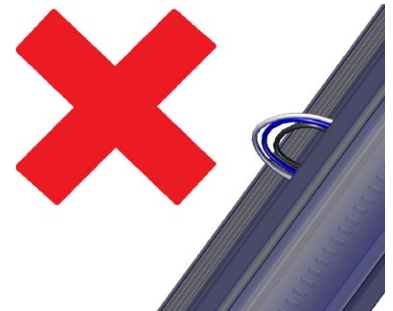

10

1. Disconnect the mains before operating the linear lighting system.
2. Type of unit and/or profile may vary.
3. Make sure poles and wiring are in correct position.
4. Insert connector to the flatcable.
5. Press and mount the fallout safety clip into

- the profile.
6. Fit the unit onto the profile under an angle.
7. Turn, press and firmly 'click' the unit into the profile.
8. In case of a sports or emergency unit, place extra safety clips onto the unit and profile, 5 on either side, equally divided.

9. **Caution:** bracket may contain sharp edges.
10. **Caution:** make sure wiring doesn't get stuck between the unit and the profile and is placed properly inside the linear lighting system.

This manual is for usage with shown product families on this page in IP54 specification only.

In combination with the following linear lighting profiles:

- **PNR-05500**
- **PNR-05515/***
- **PNR-05532/***
- **PNR-05500-B**
- **PNR-05532-B/***
- **PPR-05515/***

Magnus

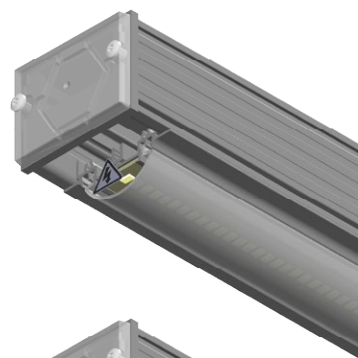

Duncan



*Indicated profiles apply, regardless of the indicated amount of spacers on the profile (PNR-.../0~/1~/2).

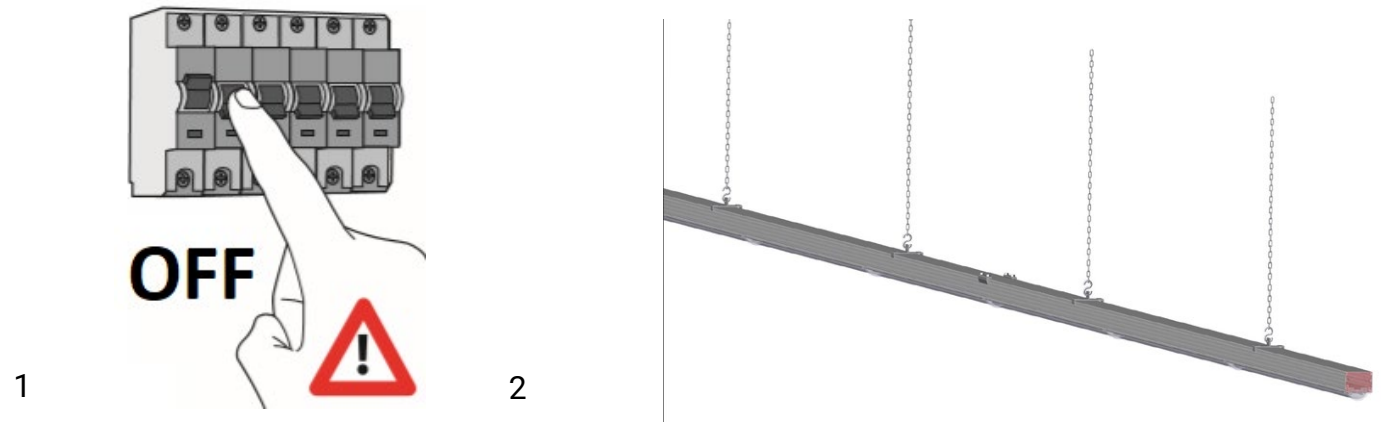

Regular conditions



Sport/Cable tray/Swimming pool/6 m+

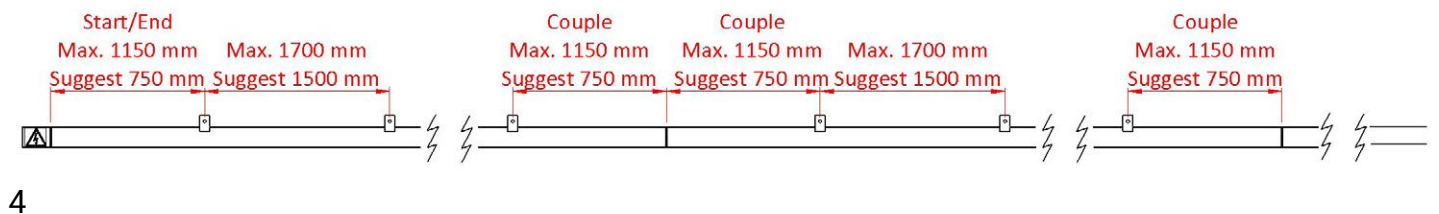

1. Disconnect the mains.

2. Example of a light-line.

3. In regular conditions:

- All line parts must be attached with at least 2 suspension points.
- Keep indicated suggested dimension for optimal suspension and quick assembly.
- Keep the same distance for the first and last suspension point.

- Keep the same distance between the coupling piece.

4. In case of Sports utility, Cable duct, Swimming pool, 6 m+:

- Sports/cable tray/swimming pool All line sections must be attached with a minimum of 3 suspension points.
- 6 m+ All line sections must be attached with a minimum of 4 suspension points.

- Keep specified suggested dimension for optimal suspension and quick assembly.

- Keep the same distance between the first and last suspension point.
- Keep the same distance between the coupler.

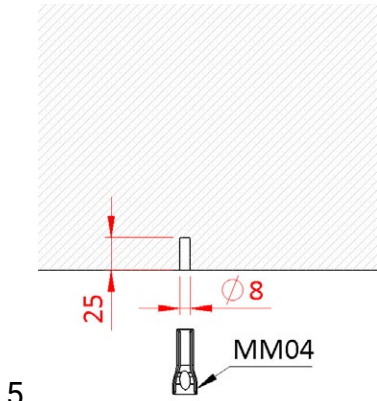

5

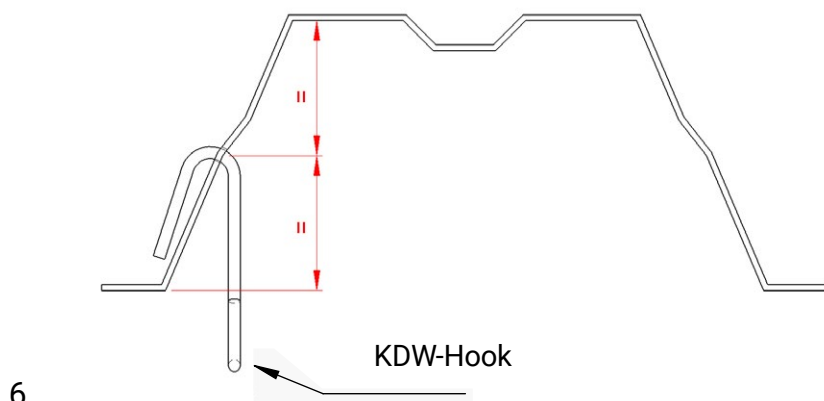

6

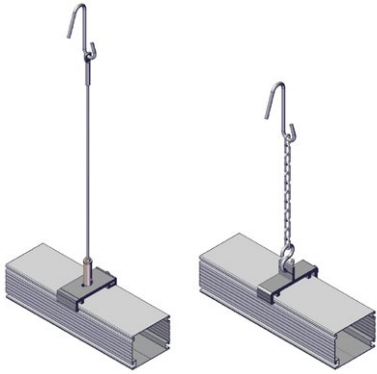

7

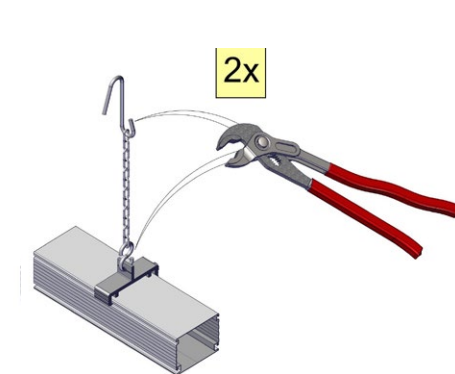

8

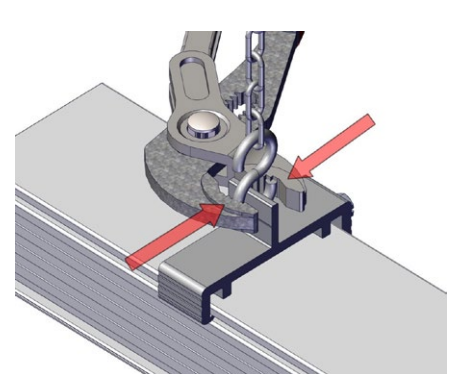

9

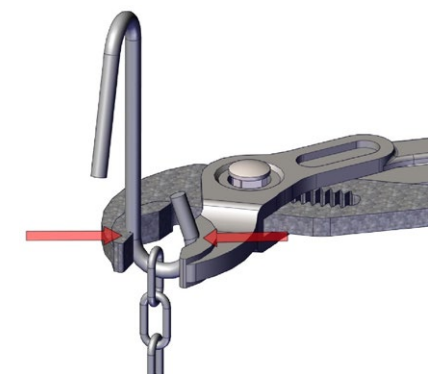

10

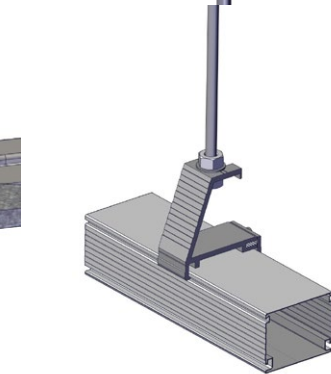

11

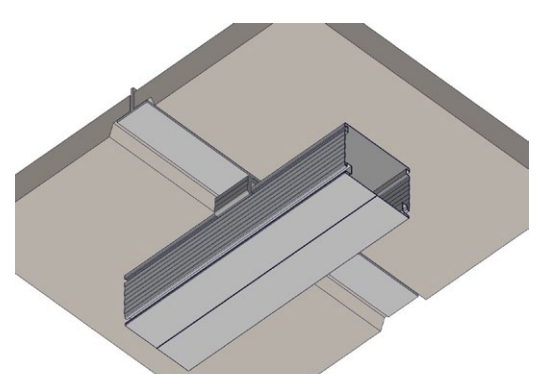

12

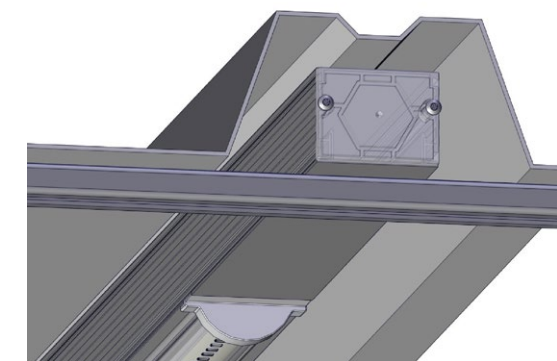

13

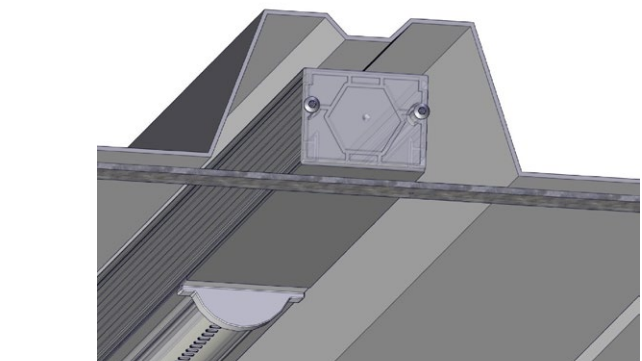

14

5. In case of mounting in concrete ceiling, Veko recommends a MM04 anchor or similar with according drill sizes.

6. In case of using a hook on a sheet piling roof structure, Veko advises to drill the hole in the center of the profile.

7. Example with KDW-hook, pendula and steelwire (left). KDW-hook, chain

and S-hook (right).

8. Always close the links of both the KDW and S-hook.

9. Close the link of the S-hook.

10. Close the link of the KDW-hook.

11. Example of mounting with threaded end.

12. Example of mounting with caddy.



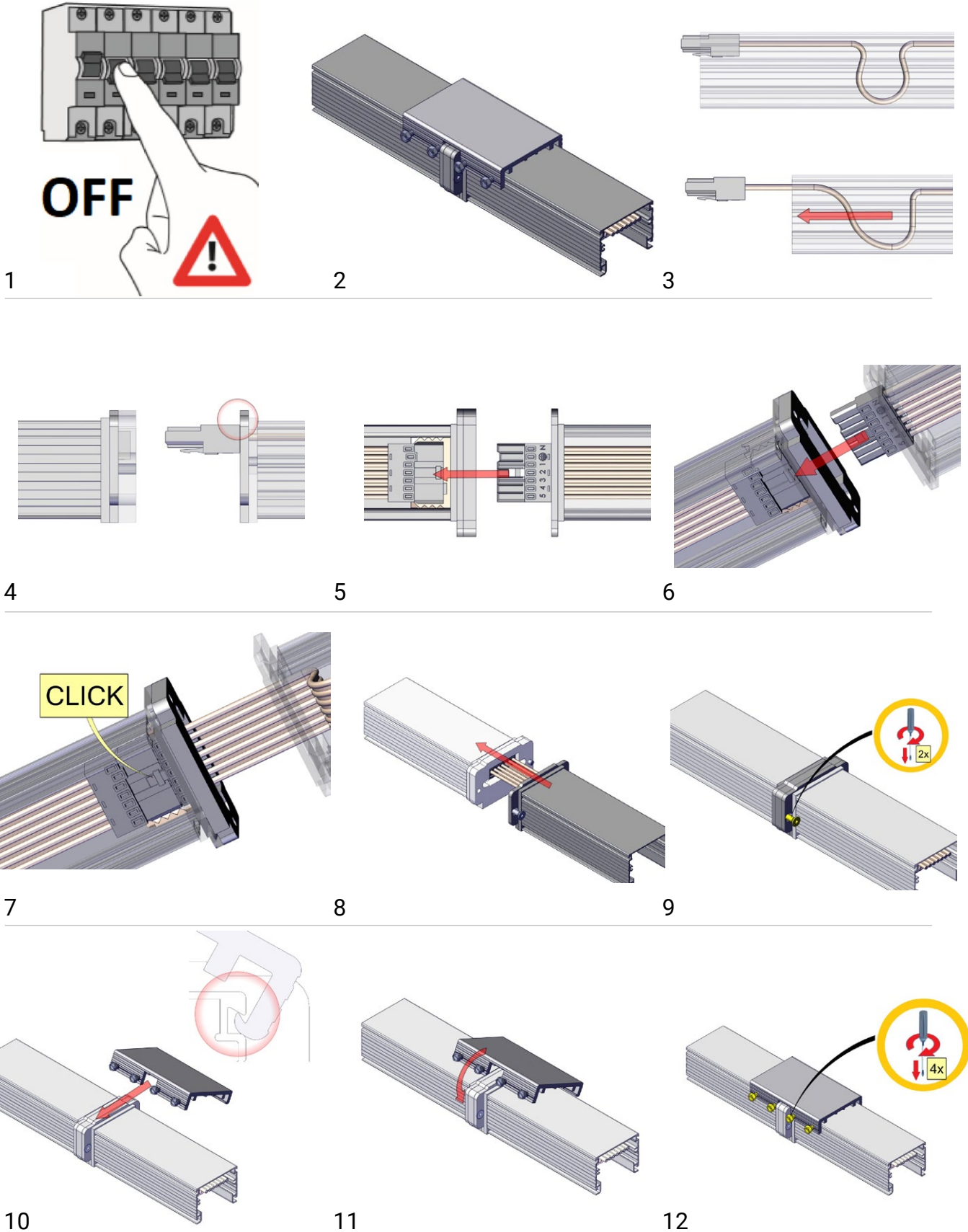





13/14. When the linear lighting is placed inside the cannellure of the sheet piling, it's recommended to use a metal strut or strip to secure the linear lighting to the metal roof structure.

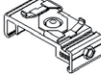
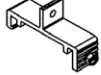
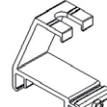
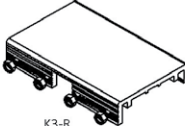

1. Disconnect the mains before operating the linear lighting system.
2. Example of connected profiles. **Note:** profile and/or brackets may vary.
3. Slide the provided bracket(s) completely onto one of the profiles.
4. The flatcable is provided with a curl for extra length for an easy connection.

5. Pull out and extend the flatcable.
6. Make sure the male connector is positioned outside the profile, with the backside onto the edge of the profile.
7. Align both profiles.
8. Insert the connector.
9. Make sure connectors firmly 'click' into each other.

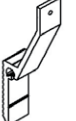
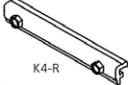
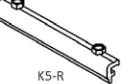
10. Slide bracket(s) back and equally divided over both profiles.
11. Tighten screws (2x).
12. Press profiles together.
13. Tighten screws (2x).

Profile	Brackets	Connecting pieces
 <p>PNR-05500</p>  <p>PNR-05500-B</p>	 <p>B3-R</p>  <p>B3-CR</p>  <p>B7-SO-R</p>  <p>B7-R</p>	 <p>K3-R</p>
 <p>PNR-05515/*</p>  <p>PNR-05532/*</p>  <p>PNR-05532-B/*</p>	 <p>B2-733-R</p>  <p>B2-SO-733-R</p>	 <p>K4-R</p>  <p>K5-R</p>
 <p>PPR-05515/*</p>	 <p>B83-PPR</p>	

* Indicated brackets for profiles with cable gutter apply, regardless of the indicated amount of spacers on the profile (PNR-.../0~/1~/2).

Note: applicability of bracket may vary, depending on the surrounding, light line configuration, light line application and/ or IP-class.

Note: K4-R and K5-R brackets are available in various lengths, so the amount of used screws may vary from illustrated as above.



Item	Qty.
Power Feed	1x
Connection plate	1x
Connector female	1x
Connector male	1x
Cable gland PG13,5	2x

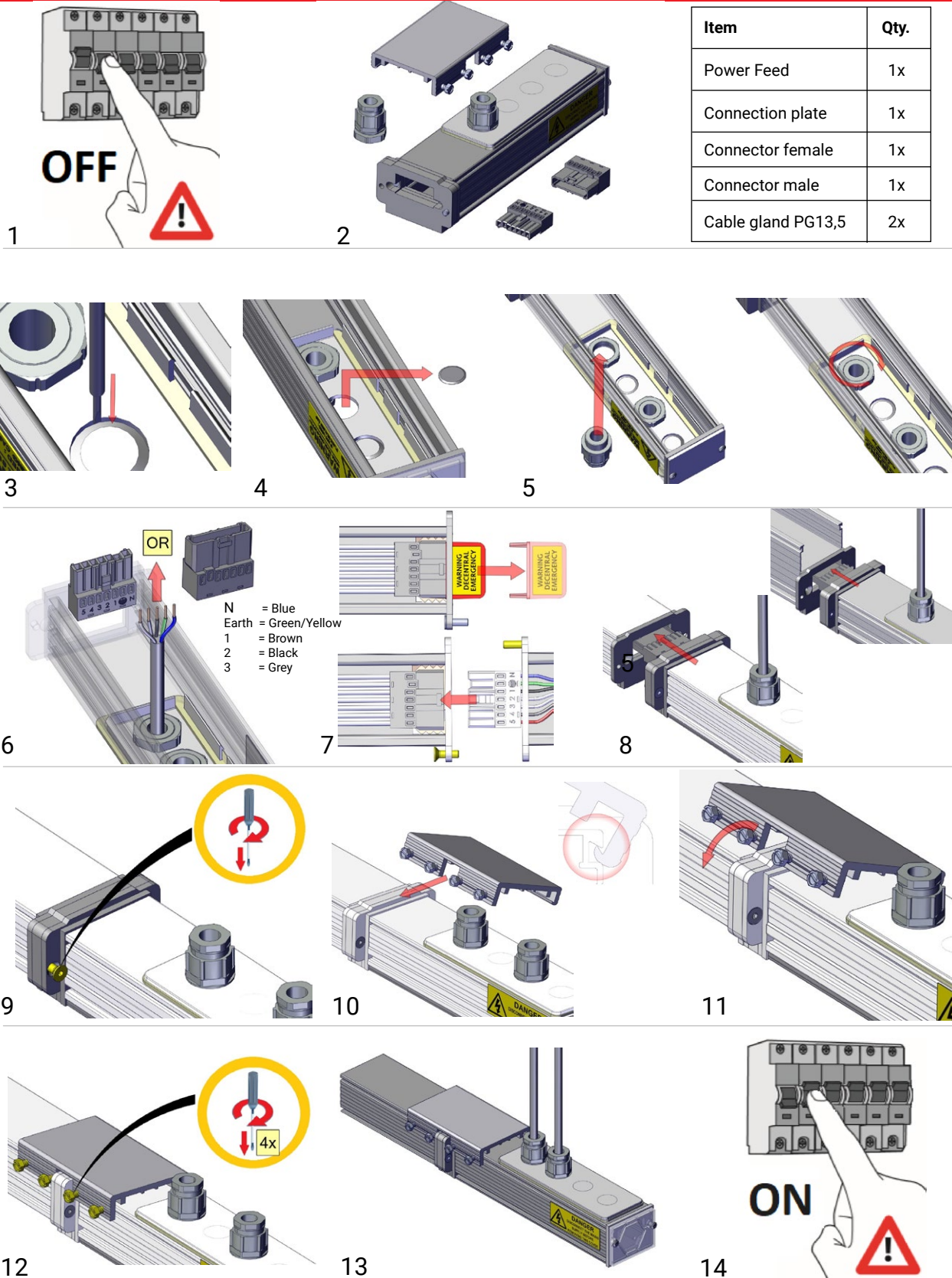

1. Switch off the mains before operating the linear lighting system.
2. Contents.
3. Use a slotted screwdriver to punch out the desired hole(s) for the cable gland(s).
4. Remove the remaining piece(s).
5. Fit the cable gland(s).
6. Fasten the cable gland nut(s).
7. Route wiring through the cable gland and fit with either male or female connector (depending on counterpart). Remove plug when final power grid connection is made.
8. Insert the connector. Connectors should firmly 'click' into each other.
9. Tighten the M5 hexagon bolts on both sides.
10. Hook the coupling plate into the profiles.
11. Rotate the plate into position.
12. Tighten the M6 bolts (4x).
13. Connect the external wiring with the connectors to the power feed.
14. After reassuring all electrical connections correctly in place, switch the mains back on.

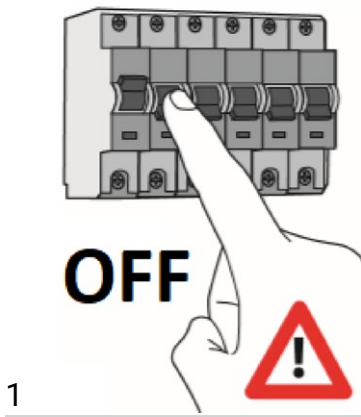

1

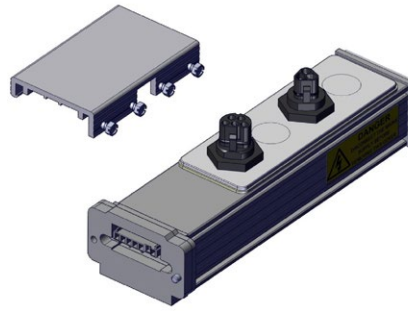

2

Item	Qty.
Power feed	1x
Coupling plate (with 4x slotted M5 bolt)	1x

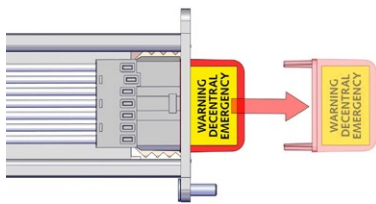

3

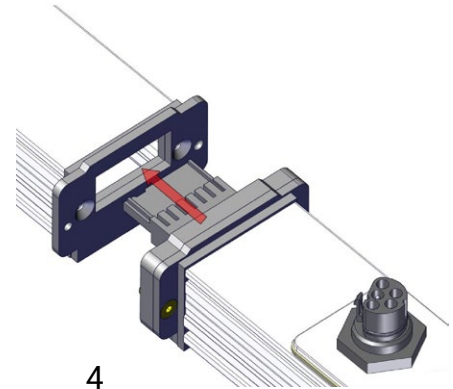
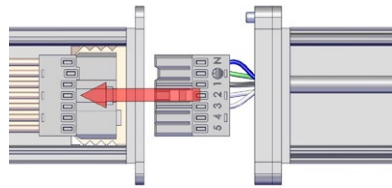

4

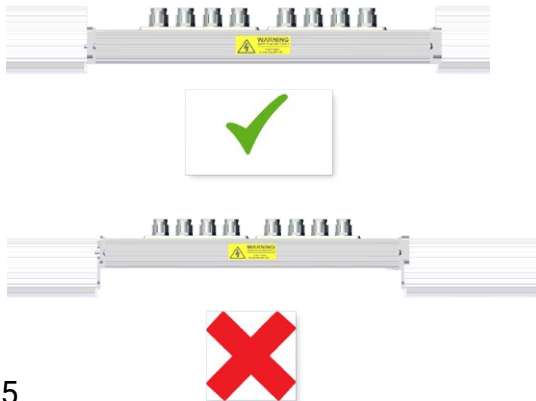

5

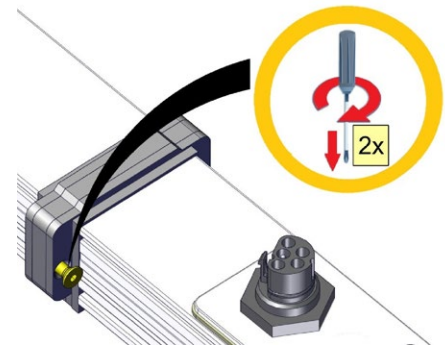

6

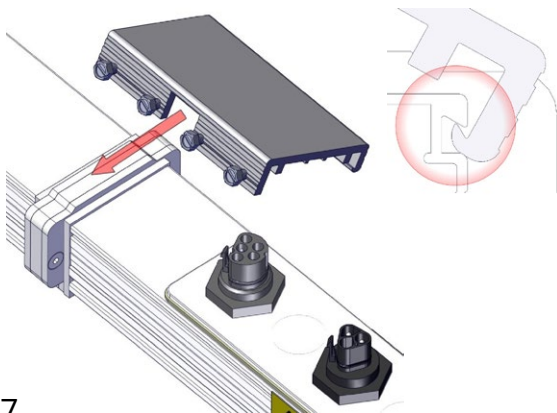

7

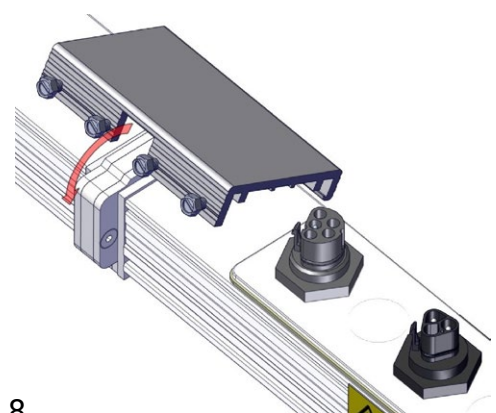

8

1. Disconnect the mains before operating the linear lighting system.
2. Contents.
3. Connect the wiring with the flatcable connectors. Remove plug when final power grid connection is made.
4. Place the feed onto the light line, aligning the connection plates. Connectors should firmly 'click' into each other.
5. In the case of a profile with a cable channel, place the centre supply at the same height as the bottom of the light line.
6. Tighten the M5 Hexagon bolts (2x) on both sides of the light line.
7. Hook the coupling plate into the profiles.
8. Rotate the plate into position.



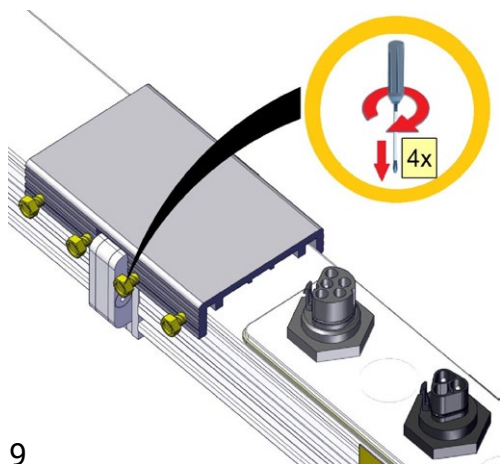

9

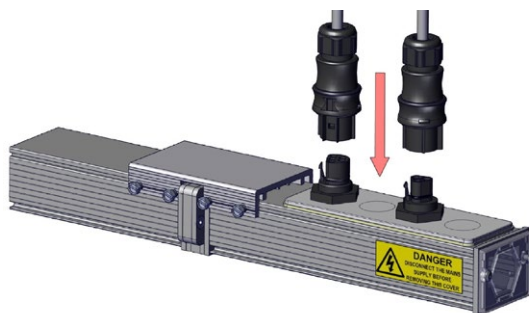

10

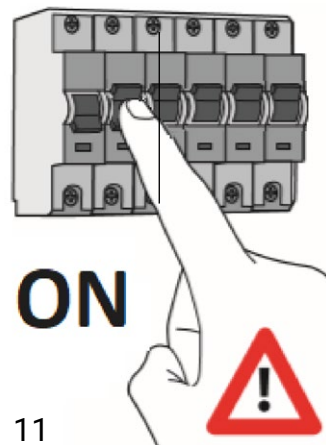

11

9. Tighten the M6 bolts (4x).
10. Connect the external wiring with the wieland connectors to the power feed.
11. After reassuring all electrical connections are correctly in place and corresponding, switch the mains back on.

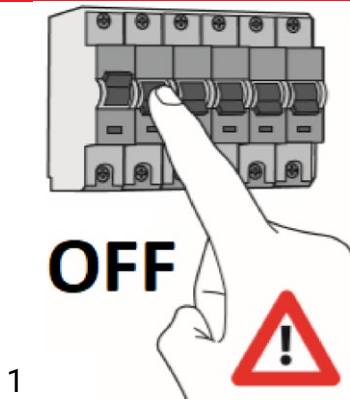

1

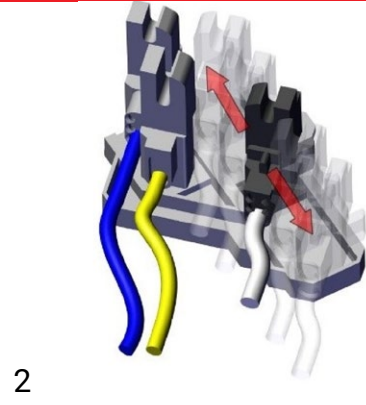

2

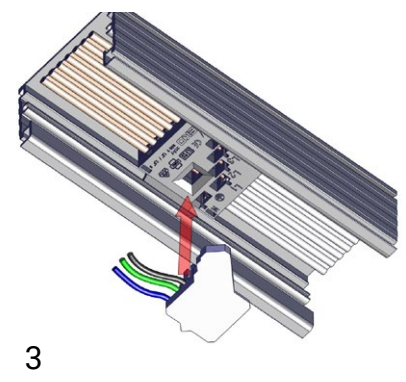

3

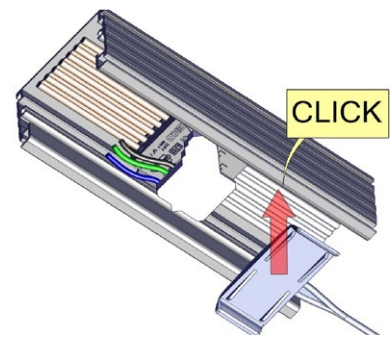

4

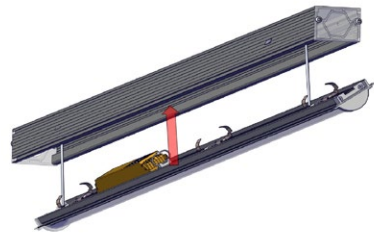

5



6

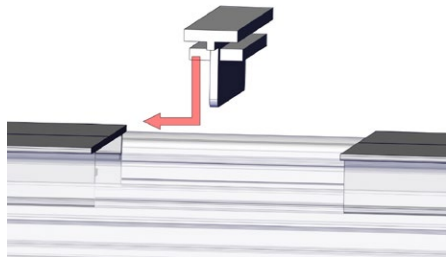

7

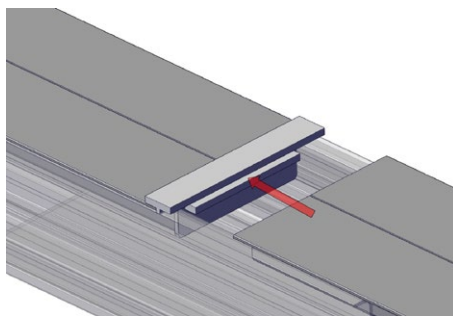

8

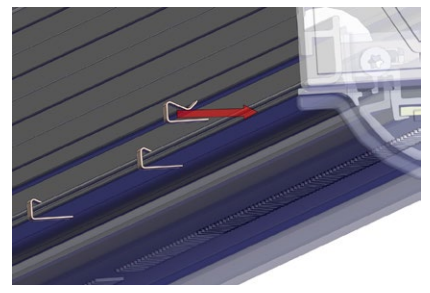

9a (sports & emergency units)

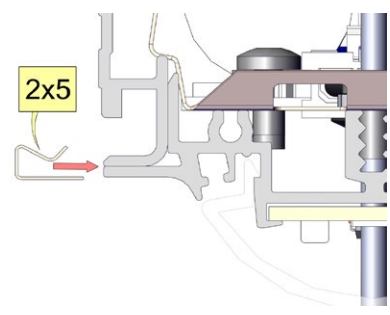

9b (sports & emergency units)

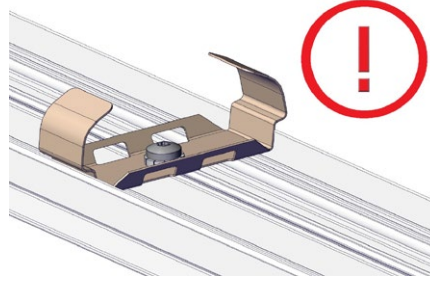

10

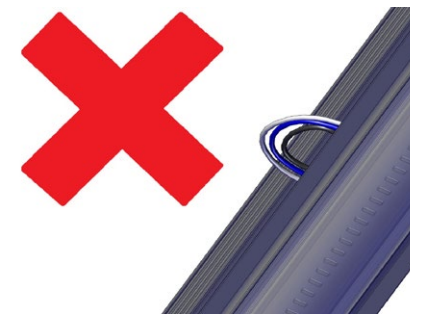

11

1. Disconnect the mains before operating the linear lighting system.
2. Make sure poles and wiring are in correct position.
3. Insert connector to the flatcable.
4. Press and mount the fallout safety clip onto the profile.
5. Fit the unit onto the profile under an angle.
6. Turn, press and firmly 'click' the unit into the

- profile.
7. Between units and/or blindplate a seal is placed to secure the IP54 standard.
8. Make sure endcaps and/or profiles are properly placed into the notch(es) of the seal.
9. In case of a sports or emergency unit, place extra safety clips onto the

- unit and light line profile, 5 on each side, equally devided.
10. Caution: bracket may contain sharp edges.
11. Caution: make sure wiring doesn't get stuck between the unit and the profile and is placed properly inside the linear lighting system.

Pool application

Not all standard components can be used in a pool environment. Due to high humidity as well as vapors of chlorine and cleaning products, high levels of corrosion can occur. To prevent corrosion, all aluminium profiles, including mounting brackets and coupling pieces (as shown on this page) will be finished with a anodized layer of at least 25µm (according to standard). To protect the LED's, the LED-board will be provided with an extra protective coating. All used suspension material (as shown on this page) will be hot dip galvanized.

Important notes







After installation, inspection off all used products is necessary due to safety regulations. This inspection should be on a regular basis and occur at least once a year. This inspection is the sole responsibility of the end user.

Applicable standards

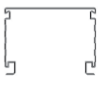
All Veko swimming pool products and components meet the following standards:

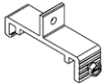
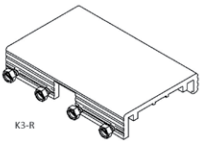
- NEN 1010 Safety for low voltage installations;
- NEN-EN 12193 Lights and lighting - sports lighting;
- NEN-EN 15288-1 Safety requirements for design;
- NEN-EN 60598-1 Lighting fixtures - Part 1: General requirements and tests;
- NEN-EN 60598-2-22 Lighting fixtures - Part 2-22: Particular requirements for emergency lighting fixtures;
- NPR 9200 Metal suspension structures and fasteners in swimming pools.

Applicable products

Profiles	Mounting	Coupling	Material
 <p>PNR-05500</p>  <p>PNR-05500-B</p>	 <p>B7-SO-R</p>	 <p>K3-R</p>	 <p>Chain</p>  <p>KDW-hook</p>  <p>S-hook</p>  <p>Screw-eye (wood)</p>

This manual is for usage with shown product families on this page in IP65 specification only.

In combination with the following linear lighting profile:

- PWDR-05500

Duncan

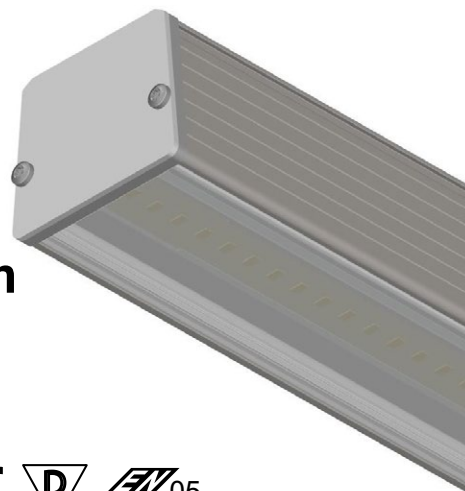

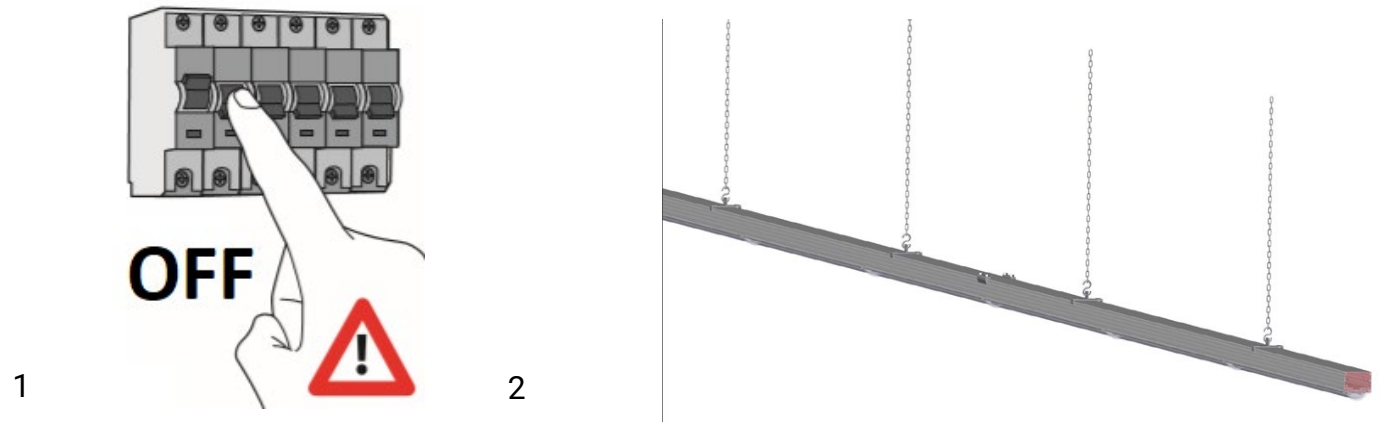

Regular conditions

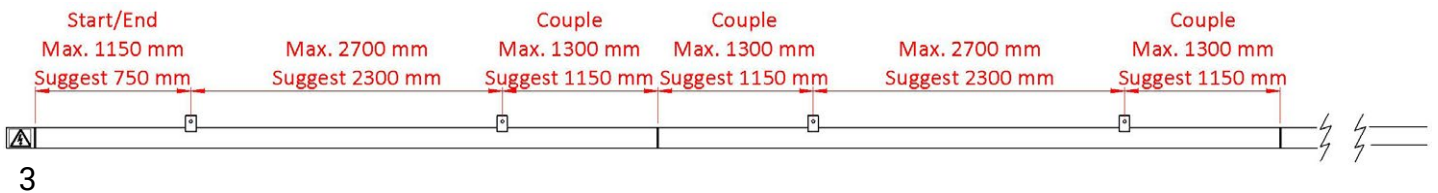

Sport/Swimming pool/6 m+

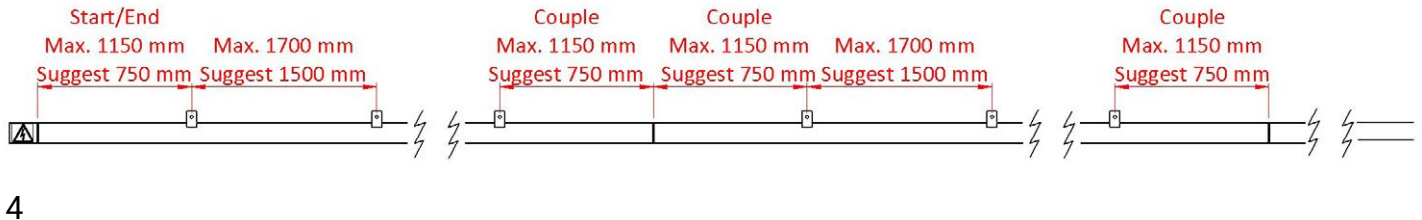

1. Disconnect the mains.

2. Example of a light-line.

3. In regular conditions:

- All line parts must be attached with at least 2 suspension points.
- Keep indicated suggested dimension for optimal suspension and quick assembly.
- Keep the same distance for the first and last suspension point.

- Keep the same distance between the coupling piece.

4. In case of Sports utility, Cable duct, Swimming pool, 6 m+:

- Sports/cable tray/swimming pool All line sections must be attached with a minimum of 3 suspension points.
- 6 m+ All line sections must be attached with a minimum of 4 suspension points.

- Keep specified suggested dimension for optimal suspension and quick assembly.

- Keep the same distance between the first and last suspension point.

- Keep the same distance between the coupler.

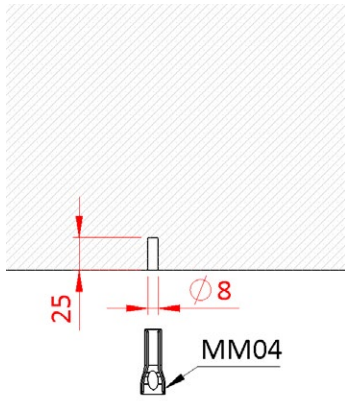

5

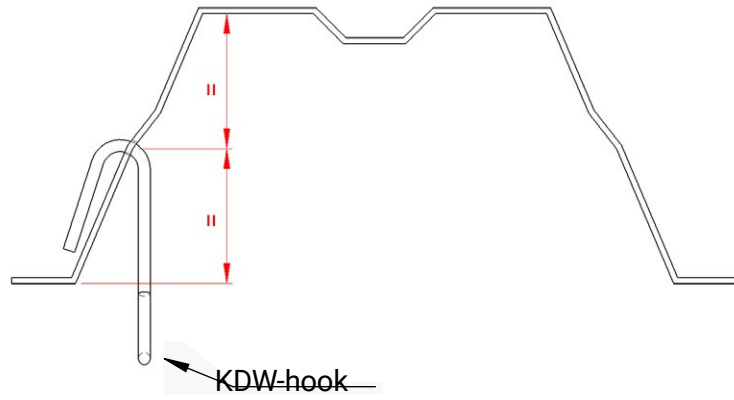

6

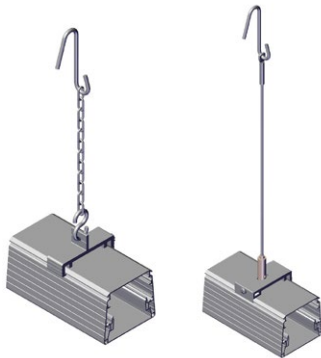

7

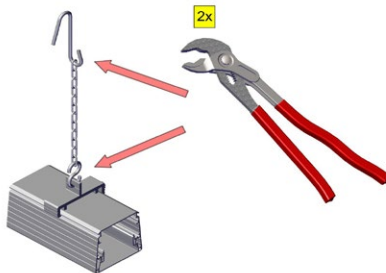

8

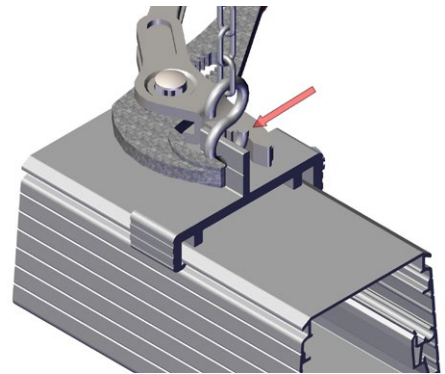

9

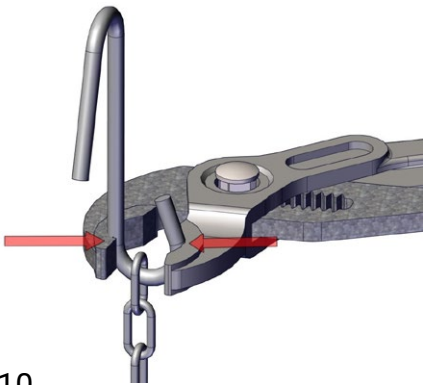

10



11

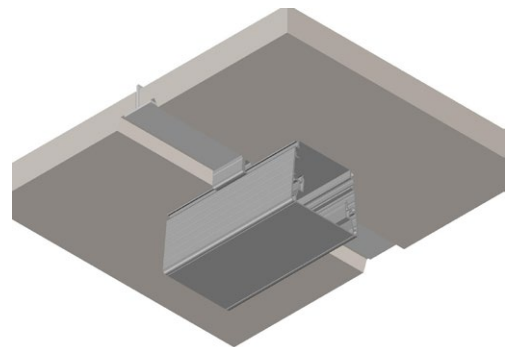

12

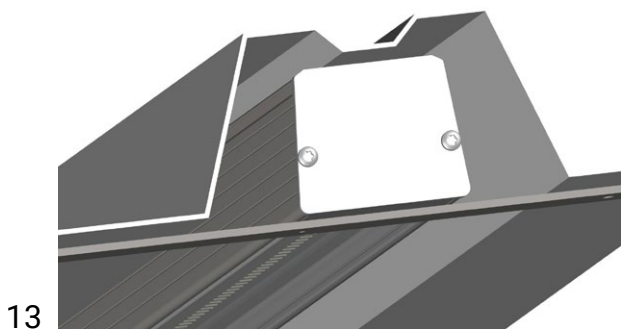

13

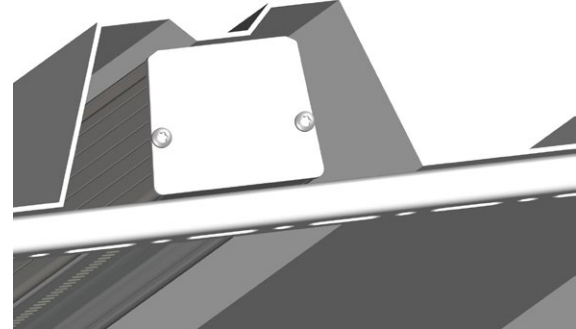

14

5. In case of mounting in concrete ceiling, Veko recommends a MM04 anchor or similar with according drill sizes.
6. In case of using a hook on a sheet piling roof structure, Veko advises to drill the hole in the center of the profile.
7. Example with KDW-hook, pendula and steelwire (left). KDW-hook, chain

- and S-hook (right).
8. Always close the links of both the KDW and S-hook.
9. Close the link of the S-hook.
10. Close the link of the KDW-hook.
11. Example of mounting with threaded end.
12. Example of mounting with caddy.

- 13/14. When the linear lighting is placed inside the cannellure of the sheet piling, it's recommended to use a metal strut or strip to secure the linear lighting to the metal roof structure.

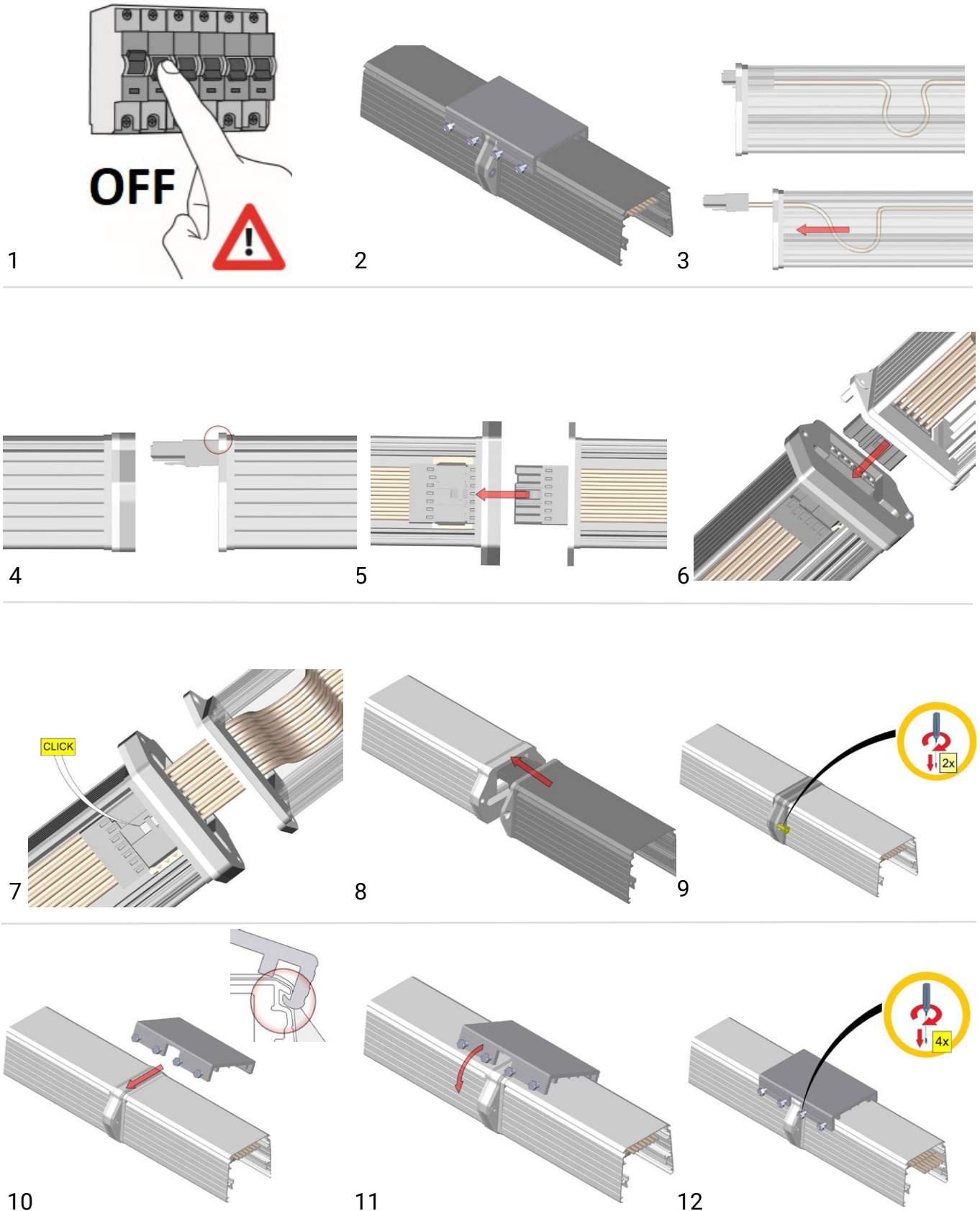

1. Disconnect the mains before operating the linear lighting system.
2. Example of connected profiles. **Note:** profile and/or brackets may vary.
3. Slide the provided bracket(s) completely onto one of the profiles.
4. The flatcable is provided with a curl for extra length for an easy connection.

5. Pull out and extend the flatcable.
6. Make sure the male connector is positioned outside the profile, with the backside onto the edge of the profile.
7. Align both profiles.
8. Insert the connector.
9. Make sure connectors firmly 'click' into

- each other.
10. Slide bracket(s) back and equally divided over both profiles.
11. Tighten screws (2x).
12. Press profiles together.
13. Tighten screws (2x).

Profile

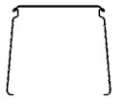

PWDR-05500

Brackets

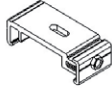

B3-R

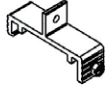

B7-SO-R

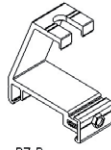

B7-R

Connection pieces

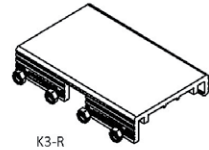

K3-R

Note: applicability of bracket may vary, depending on the surrounding, light line configuration, light line application and/ or IP-class.

Item	Qty.
Power Feed	1x
Connection plate	1x
Connector female	1x
Connector male	1x
Cable gland PG13,5	2x

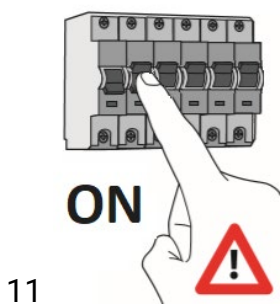
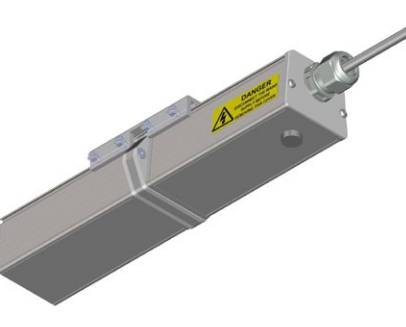
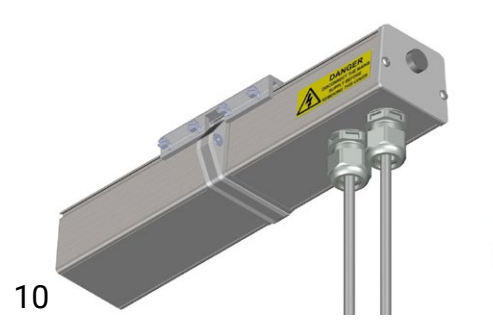
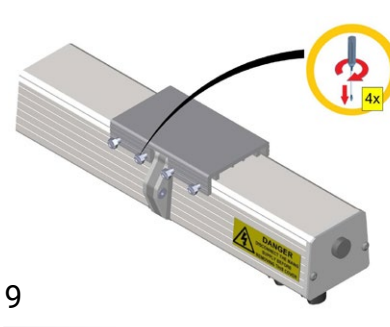
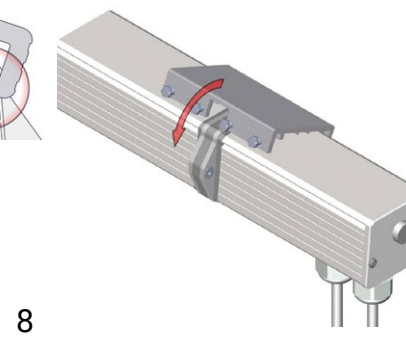
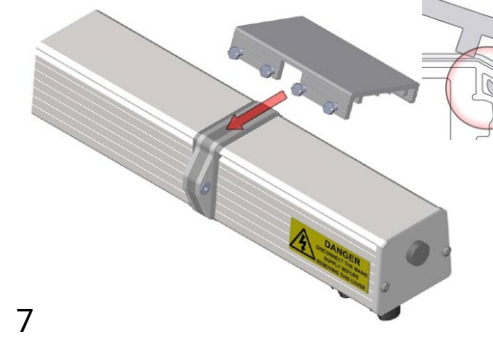
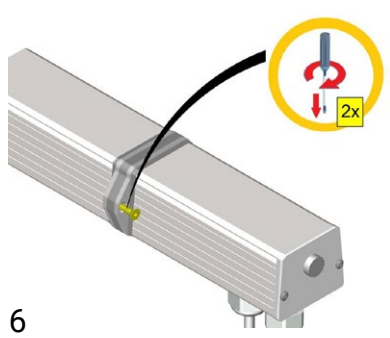
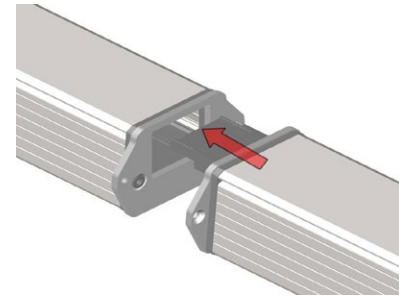
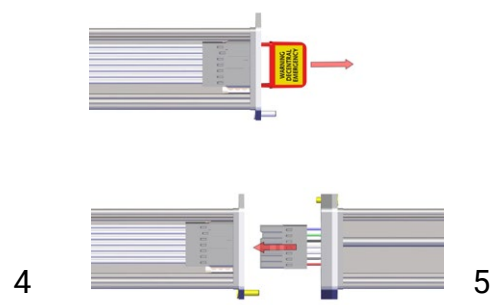
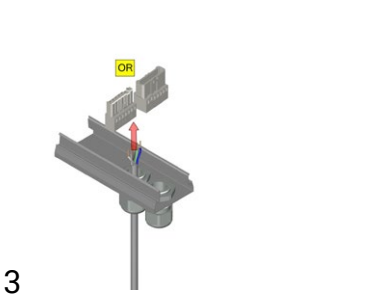
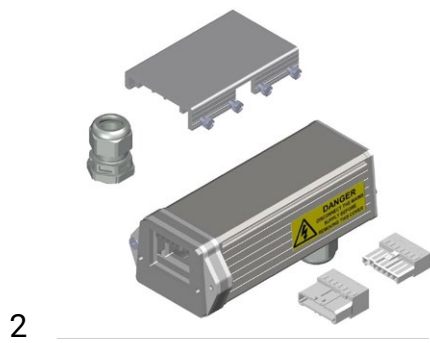
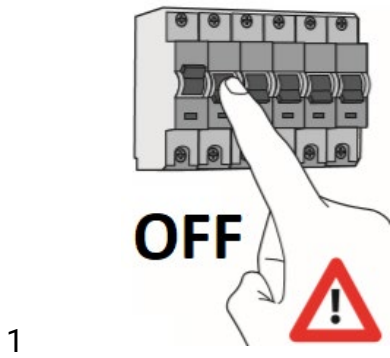

- Switch off the mains before operating the linear lighting system.
- Contents.
- Route wiring through the cable gland and fit with either male or female connector (depending on counterpart on the linear lighting system).
- Remove plug when final power grid connection is made. Insert the connector.
- Connectors should firmly 'click' into each other.
- Tighten the M5 hexagon bolts on both sides.
- Hook the coupling plate into the profiles.
- Rotate the plate into position.
- Tighten the M6 bolts (4x).
- Connect the external wiring with the connectors to the power feed.
- After reassuring all electrical connections correctly in place and corresponding switch the mains back on.



Item	Qty.
Power feed	1x
Coupling plate (with 4x slotted M5 bolt)	1x

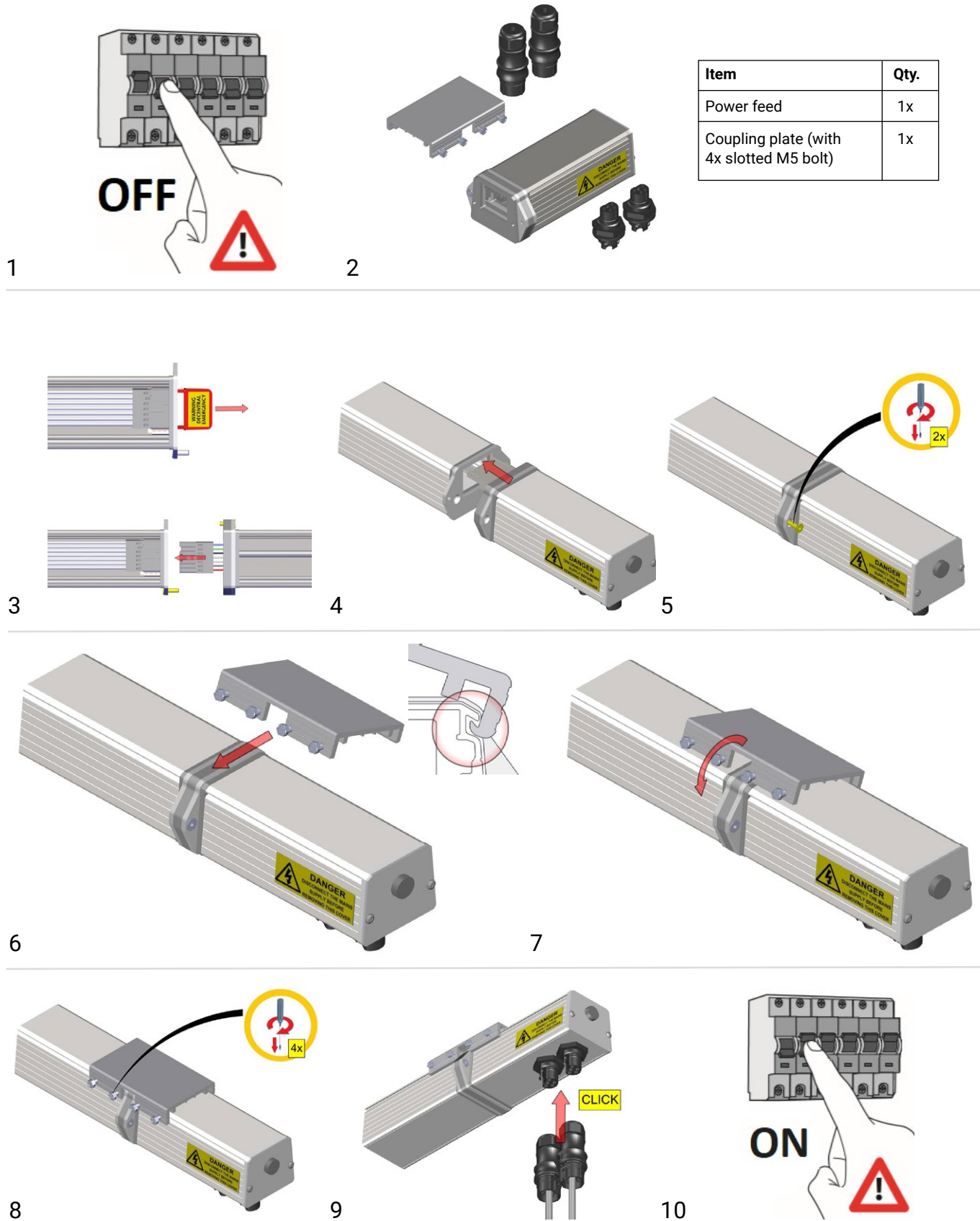

1. Disconnect the mains before operating the linear lighting system.
2. Contents.
3. Remove plug when final power grid connection is made. Connect the wiring with the flatcable connectors.
4. Connectors should firmly 'click' into each other.
5. Place the feed onto the light line, aligning the connection plates. Tighten the M5 Hexagon bolts (2x) on both sides of the light line.
6. Hook the coupling plate into the profiles.
7. Rotate the plate into position.
8. Tighten the M6 bolts (4x).
9. Connect the feed to the main grid using the Wieland connectors.
10. After reassuring all electrical connections are correctly in place and corresponding, switch the mains back on.

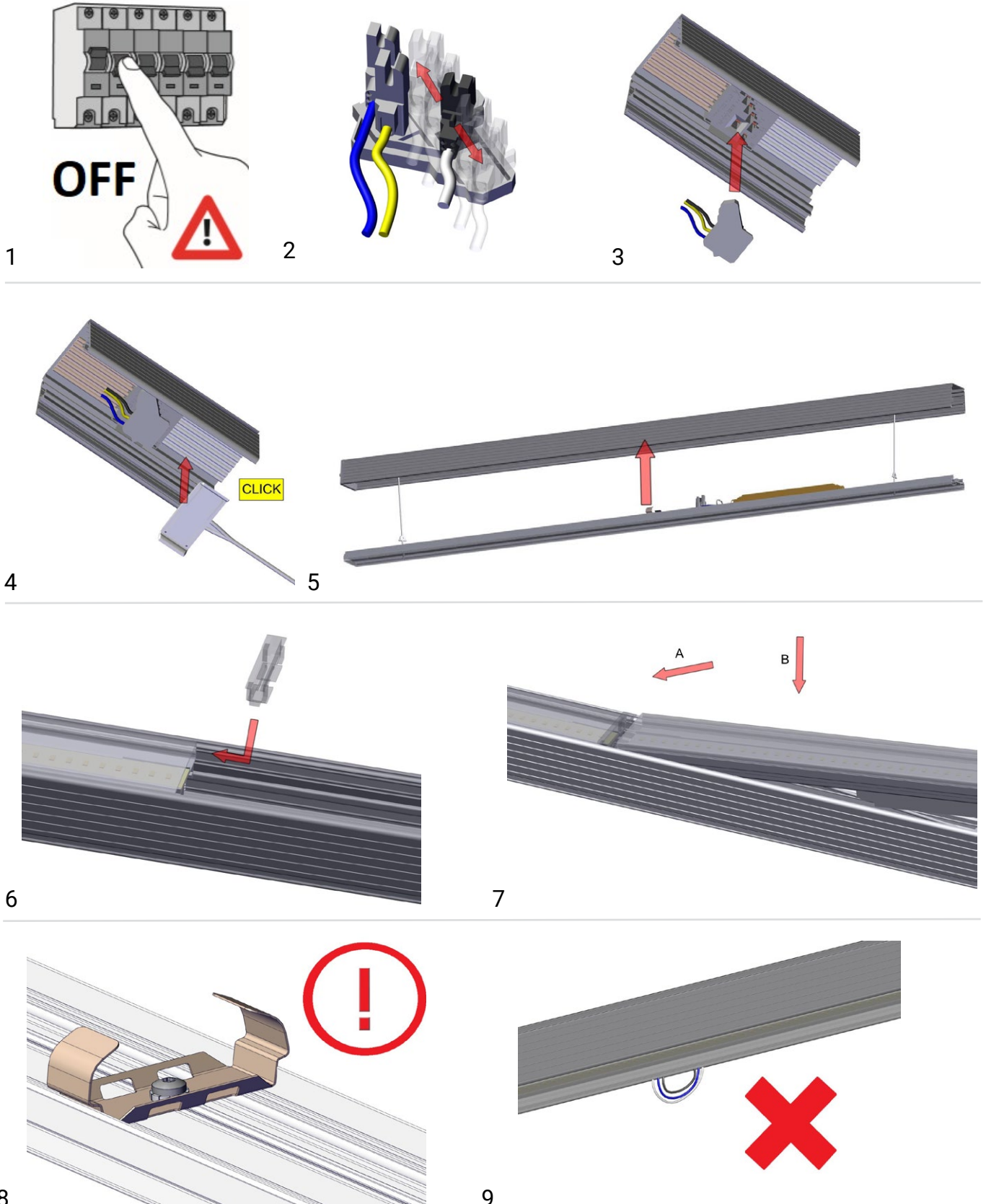

1. Disconnect the mains before operating the linear lighting system. **Note:** Type of unit and/or profile may vary.
2. Make sure poles and wiring are in correct position.
3. Insert connector to the flatcable.
4. Press and mount the fallout safety clip into the profile.

5. Press the unit into the profile.
6. Mount the sealing between units and/or blindplate to secure the IP65 standard.
7. Press the unit into the profile. Make sure the blindplate and/or unit are properly placed into the notch(es) of the seal.
8. **Caution:** bracket may contain sharp edges.
9. **Caution:** make sure wiring doesn't get stuck

between the unit and the profile and is placed properly inside the linear lighting system.

Pool application

Not all standard components can be used in a pool environment. Due to high humidity as well as vapors of chlorine and cleaning products, high levels of corrosion can occur. To prevent corrosion, all aluminium profiles, including mounting brackets and coupling pieces (as shown on this page) will be finished with a anodized layer of at least 25µm (according to standard). To protect the LED's, the LED-board will be provided with an extra protective coating. All used suspension material (as shown on this page) will be hot dip galvanized.

Important notes



After installation, inspection of all used products is necessary due to safety regulations. This inspection should be on a regular basis and occur at least once a year. This inspection is the sole responsibility of the end user.

Applicable standards

All Veko swimming pool products and components meet the following standards:

- NEN 1010 Safety for low voltage installations;
- NEN-EN 12193 Lights and lighting - sports lighting;
- NEN-EN 15288-1 Safety requirements for design;
- NEN-EN 60598-1 Lighting fixtures - Part 1: General requirements and tests;
- NEN-EN 60598-2-22 Lighting fixtures - Part 2-22: Particular requirements for emergency lighting fixtures;
- NPR 9200 Metal suspension structures and fasteners in swimming pools.

Applicable products

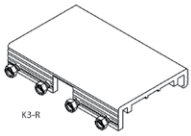
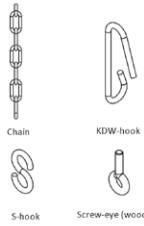
Profiles	Mounting	Coupling	Material
 <p>PWDR-05500</p>	 <p>B7-SO-R</p>	 <p>K3-R</p>	 <p>Chain KDW-hook S-hook Screw-eye (wood)</p>

MANUAL INSTALLATION VEKO SENSOR

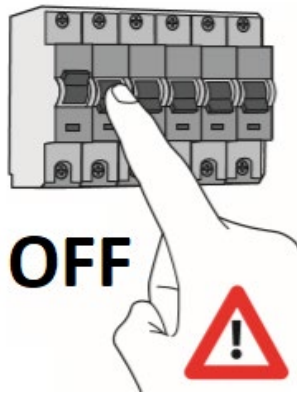

1



2

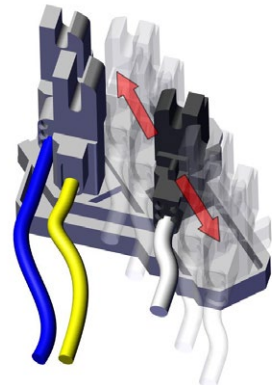

3

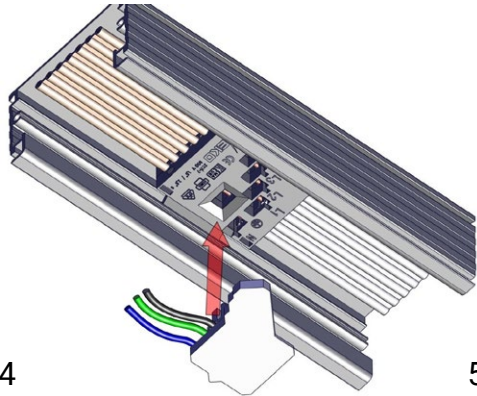

4

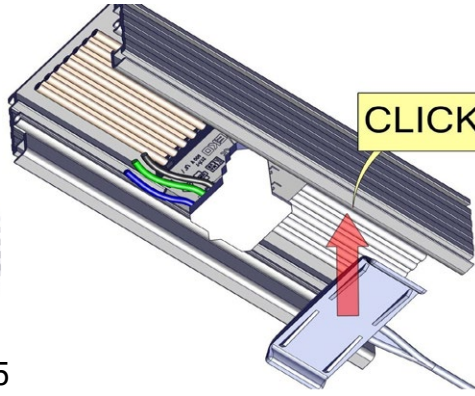

5

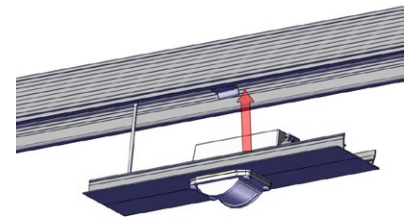

6

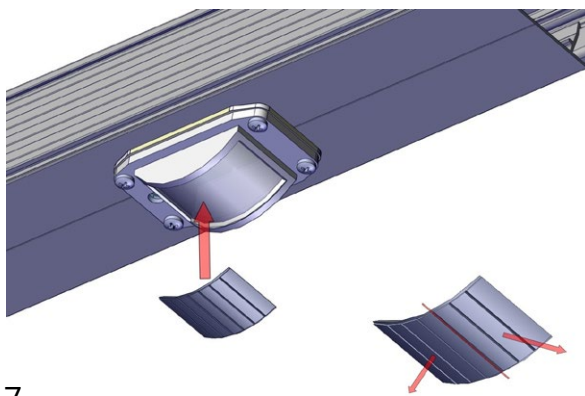

7

Technical data

Power (W)	1,5 W < 4 W (Switched off - < on)
Voltage (V)	220-240 V
Length (mm)	300 mm
Frequency (Hz)	50 ÷ 60 Hz
Circuit	6 A
Sensitivity settings*	5 (standard max. sensitivity)
Twilight circuit*	Adjustable in 9 steps 0-1.000 Lux
Switch-off delay relay*	Relay 0-99 minutes
Environment application	-25 °C - + 35 °C
Corridor function / dynamic switch (example: 10-100 %)	In combination with DALI driver and control gear
Programming	Readout and re-programmable by colour coding with LED in sensor
ENEC certification	In application at DEKRA
Warranty	5 years

8

* does not apply to the Veko System Sensor. This is set from the software.

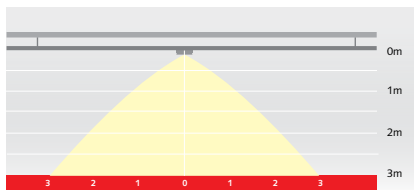

MD-L-R

MD-L-N

- Length -

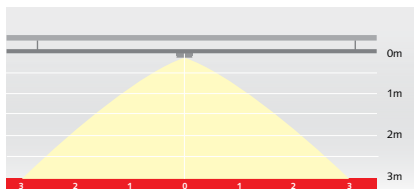
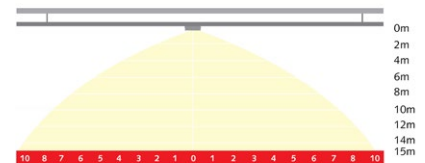

- Width -

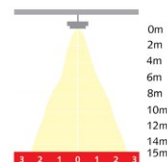

9

This page applies to all MD-L subtypes and configurations.

1. Switch off the power supply before connecting the light system.
2. Example of a sensor. Note: sensor type and/or linear lighting profile may vary.
3. Ensure correct position of poles and wiring.
4. Plug the connector into the flat cable.

5. Press and attach the safety clip for emergencies in the continuous-row lighting profile.
6. Install the sensor in the profile.
7. In the case of the narrow lens, a cover can be used to limit the range of the sensor, if necessary. This cover can be cut to size with pliers or scissors on the break line to achieve

- the desired range and angle of the sensor.
8. Technical data.
9. Sensor range: MD-L-R (round lens)
MD-L-N (narrow lens)

MANUAL CONFIGURATION MD-L-R / MD-L-N

When the MD-L-R / MD-L-N is plugged into the light line and connected to power, it will fully function and perform as a motion detection sensor. All Veko sensors have a standard configuration. Some of these features are manual adjustable with a remote control (TR67). These functions are described in the manual below. You can use this manual on site when a re-configuration is needed, a maintenance test is required, or the lights need to be manually overruled.

<p>1 Switch off delay*</p> <p>The duration of switch on after detection can be set between 1 and max. 99 minutes.</p>	<p>Red Fast Blink, Blue Solid, 0 1 = 1 minute, 9 9 = 9 minutes, 21 = 21 minutes, 3 digits = cancel, OK Save, C Cancel, 1x, Red, Green, Red, Blue 3 flashes / Colour, 1x.</p>
<p>2 Sensitivity detection*</p> <p>The sensitivity of the movement detection can be adjusted according to your preferences.</p>	<p>Red Fast Blink, Green Solid, 0 1 = Low sensitivity, ... 5 = High sensitivity, OK Save, C Cancel, 1x, Red, Green, Red, Blue 3 flashes / Colour, 1x.</p>
<p>3 Sensitivity twilight mode*</p> <p>The sensitivity of switch on relative to the available daylight can be adjusted.</p>	<p>Red Fast Blink, Red Solid, 0 1 = 100 Lux, ... 9 = 900 Lux, OK Save, C Cancel, 1x, Red, Green, Red, Blue 3 flashes / Colour, 1x.</p>
<p>4 Sensitivity twilight mode off*</p> <p>Switch off twilight mode. Note: standard/factory setting is: off.</p>	<p>Red Fast Blink, Red Solid, OFF, Red, Green, Red, Blue 3 flashes / Colour, 1x.</p>
<p>5 Check the programmed setting* of:</p> <p>5.1 Time frame light on</p> <p>5.2 Detection accuracy</p> <p>5.3 Sensitivity twilight mode</p> <p>5.4 Hardware version</p>	<p>Green Fast Blink, Blue Solid, Green, Green, Green, Red, Blue, Green, Blue, H, Blue.</p> <p>Flashes blue colour X times for set duration. Long blink for first digit and short blink for second digit.</p> <p>Flashes blue colour for 1 second pulse mode.</p> <p>Flashes green colour X times for set detection sensitivity.</p> <p>Flashes red colour X times for set Lux level.</p> <p>Flashes 3x red/blue colour when twilight mode is switched off.</p> <p>1x= Relay Sensor 2x= Veko System Sensor 3x= Smart Cast Sensor</p>
<p>6 Overrule function</p> <p>Overrule all current settings and switched all lighting on or off for a set amount of hours.</p>	<p>Blue Fast Blink, Blue Slow Blink, 0 1 = 1 hour, ... 9 = 9 hours, C Return to normal, ON Lighting switched ON for x hours, Green Solid, OFF Lighting switched OFF for x hours, Red Solid, Save, Return to normal, 1x.</p>
<p>7 Test functions</p> <p>The lights will flash on and off for 10 sec.</p>	<p>Blue 3x Flash, Hold until light responds, 8 Factory settings, Set back all functions to factory settings, Green/Red Blink, OK Save, C Return to normal, 1x.</p>

* Automatically returns to normal mode, if there is no activity for 20 seconds. Settings will be saved.



DECENTRAL EMERGENCY LIGHTING

Logbook

NEN-EN 1838 & NEN-EN-IEC 60598-2-22



1

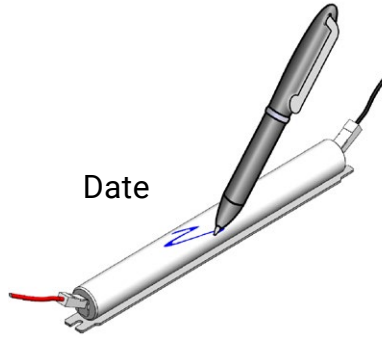

Date

2

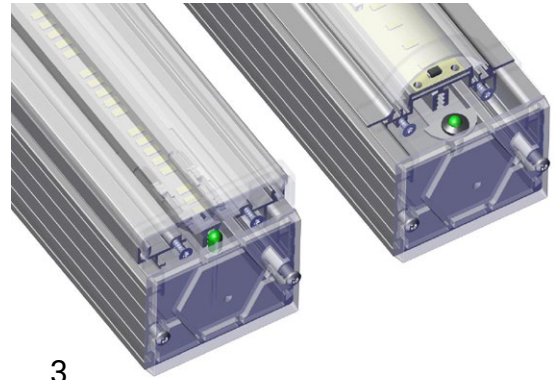

3

4 Trustsight

LED color / flashing	Cause
Green / continue	System OK, battery fully charged
Off	Main off, EM position, Rest position, test in progress
Green / slow flashing	System OK, battery is charging
Green / fast flashing	System OK, recently tested
Red / continue	No / wrong / bad battery connected
Red / fast flashing	Battery end of life, charger fault
Red / slow flashing	Wrong LED load connected
Red-green / fast flashing	DALI device identification
Green / short flashing	Battery detection

5 ELP

LED color / flashing	Cause
Green / continue	System OK, battery fully charged
Green / slow flashing	Duration test in progress, commissioning in progress
Red - Green / Slow flashing	DALI device identification
Off	Main off, EM position, Rest position
Green / slow double flashing	Rest mode
Red / slow flashing	Malfunction of lighting
Red - green / fast	Battery fault
Green / short flashing	Battery charger fault

1. Owner of the building/ luminaires (or acting party) is obliged to keep a logbook according to NEN-EN 1838 & NEN-EN-IEC 60598-2-22.
2. Before installing the emergency unit or replacing the battery, write the installation date onto the battery.
3. Example of emergency unit indication LED.
4. LED status indicator - Index Trustsight
5. LED status indicator - Index ELP

CLEVER
SWIFT
SOLID

DECENTRAL EMERGENCY LIGHTING

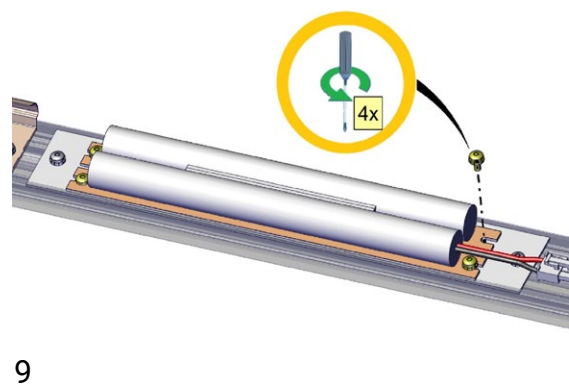
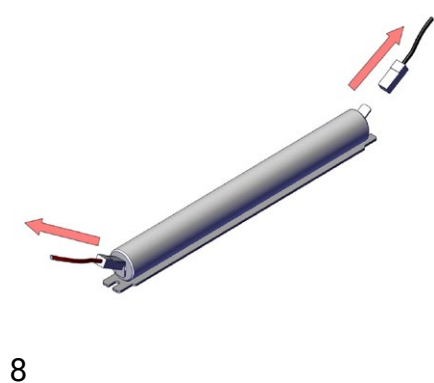
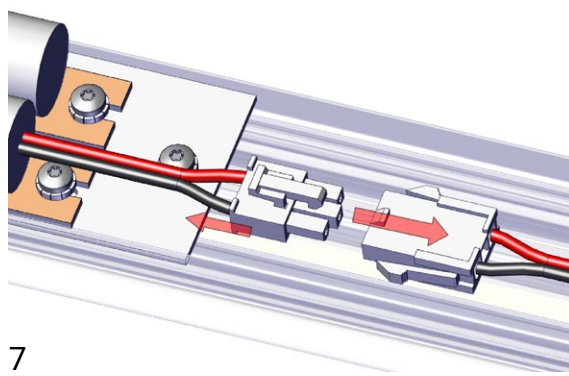
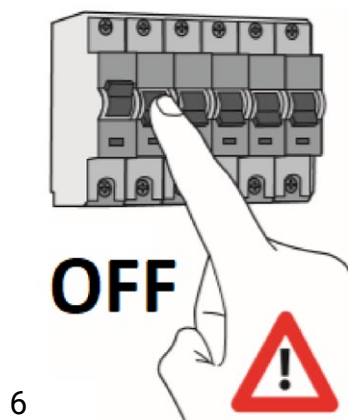

6. Disconnect the mains before operating the linear lighting system.
7. Disconnect the battery from the emergency module.
8. Type and/or quantity of batteries may vary as well.

9. Unscrew the battery from the mounting plate and replace. Re-tighten screws and reconnect the battery wires with the emergency module. Replace emergency unit as described in this manual.

DECENTRAL EMERGENCY LIGHTING

Self-test according IEC 62034

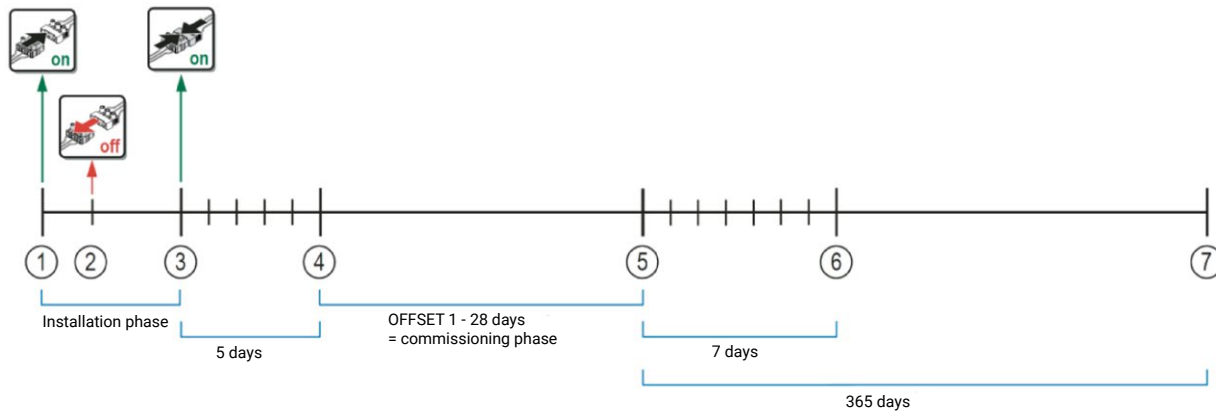

Emergency Lighting

The owner of the building / luminaires (or acting party) is obliged to keep a logbook according to NEN-EN 1838 & NEN-EN-IEC 60598-2-22 of their emergency installation. The logbook must state:

- Installation date of the luminaires;
- Document regular inspection routines;
- Document replacement and/or maintenance;
- The logbook should be available for a minimum period of three years;
- Emergency back-up facilities are provided with at least one continuous circuit (phase) connection;
- When installing emergency lighting(s), ensure that a continuous power supply is available and connected;
- After installation, avoid interruptions in this continuous power supply.

In case of a stand-alone emergency:

- The emergency light can operate between +5 °C and +25 °C with a maximum humidity of 65 % ± 5 %;
- Before installing the emergency lighting, write the installation date on the battery;
- The luminaires must be installed within a period of 3 months after production of the luminaires;
- If the luminaires are not connected within a period of 1 month, disconnect the battery;
- After complete installation of all emergency lighting, a period of 48 hours is required to fully charge the batteries, thereafter, the operation of all luminaires should be documented for the building operator;
- Repeated power cuts will drastically reduce the life of the batteries;
- The emergency light(s) should be discharged for a maximum of 4 cycles per year plus 2 cycles during commissioning.

DALI

Each DALI emergency device is individually addressable on the DALI bus and each device can be individually commanded to perform an emergency test. Thus, instead of testing all emergency luminaires in one zone together, each emergency luminaire in the zone can be tested at a different time, ensuring the safety of the zone at all times.

If the emergency lighting and normal drivers in a luminaire are both DALI devices, each luminaire can be addressed separately on the same DALI bus. This makes it possible to use common wiring for both normal lighting control and emergency test control. During a fault in the permanent power supply, the TrustSight or ELP driver operates autonomously for the escape lighting regardless of the state of the DALI bus. The TrustSight or ELP DALI version is equipped with a self-test function according to IEC 62034. Automatic tests will be performed according to the duration test (every 52 weeks) and programmable interval times (every 7 days). The DALI standard operating mode is the duration test performed as long as the nominal duration (3 hours). The automatic duration test always runs until the battery is fully discharged. Full discharge is recommended for battery maintenance.

Conditions for endurance test/functional test

The TrustSight or ELP driver must be permanently connected to the mains during a duration test or functional test and the battery must be fully charged. When planning a duration or functional test, the operation of the AC driver is also checked. When the AC driver is energised, the test can be repeated up to 3 days later (in 24/7 lighting situations). When the AC driver has been switched off for at least 2 hours, the test is started.

GENERAL DISCLAIMER

Product specifications

- Ambient working range -25 °C-+35 °C (-13 °F - 95 ° F)
- Storage -25 °C-+35 °C (-13 °F - 95 ° F)
- Rated voltage range 220 V~240 V~ 50/60 Hz
- Relative humidity 10 %-85 % RH - not condensing
- Cable specification 7&3 pin suitable for solid wiring (Ø1.5-2.5 mm²)

Important

- Caution, risk of electric shock!
- Hot plug-in is not an option and may cause damage to the luminaire.
- Disconnect the mains before installing or modifying this product.
- Installation and commissioning of the luminaire must be performed by a qualified electrician in accordance with all national and/or local regulations.
- Install all individual light lines before connecting to the grid.
- NEVER install this product without reading this installation guide.
- NEVER stare into this product when switched on.
- NEVER modify or alter this product, this will result in loss of warranty.
- Read the product labels carefully for all product details.
- This product is not suitable for signal functions, in case of emergency function see next paragraph.
- This product is not suitable for outdoor use.
- This product is not suitable for off-grid power solutions.
- On this product no condensation is allowed during storage, operation and application.
- When operating the electrical connections and connecting to the mains or grid always work according to standard NEN 1010 and NEN 3140.

Note

- A Veko linear lighting system is considered as a single luminaire (a 'closed' system) and not an electrical installation at itself.
- The light source of this product is custom made and shall only be replaced by the manufacturer or his service agent.
- At end of life, the whole product needs to be replaced.
- This product is not intended for household usage.
- Take care with the usage of power cables and prevent damage to the cables when installing them.
- Avoid touching the product if active, it might cause harm due to heat
- When the product is unpacked, take care of placement. Do not let the product rest on top of the optics, damage to optics will result in light output loss.
- The manufacturer is not liable for damages resulting from improper or faulty installation or operation from unauthorized modifications to the luminaire.
- Specifications are subject to change without notice! If you have questions please contact the manufacturer.
- Take appropriate precautions: wear gloves.
When adjusting the length of the light lines between the walls, an expansion coefficient of 24×10^{-6} (2.4 mm per 100 m per °C) should be taken into account.
- Keep at least one copy of this document as future reference material.

Cleaning

- ALWAYS switch off the power to the product before cleaning.
- This product can be cleaned with a damp cloth.
- Choose cleaning materials which are suitable for plastic.
- Do not use coarse or rough cleaning tools on this product.
- Do not use bleach or solvents on this product.
- Do not use any type of high pressure equipment to clean this product.
- Do not submerge this product.

NOTES

A series of horizontal dotted lines for taking notes.



NOTES

A series of horizontal dotted lines for taking notes, spanning the width of the page.

